

SMART LIFTING SOLUTIONS



A WORLD CLASS
GLOBAL PARTNER



Made in Sweden

CONTENT

▶ EDMOLIFT AB

- 10 Welcome to our world
- 12 Smart Lifting Solutions
- 14 Good ergonomics
- 16 Innovation is our watchword
- 18 UC60
- 20 Environmental investment
- 22 Lifting solutions for every need
- 24 Service & support
- 26 A journey through time with Edmolift

▶ EDMOLIFT GUIDE

- 30 What is a lift table
- 31 Benefits with lift tables
- 32 Lift table models
- 33 Checklist for effective handling of materials
- 34 How to choose the right lift table
- 35 Pit drawing and surface treatment
- 36 UC60 - plug and play
- 38 Safety regulations
- 40 Work positioners and more lifting solutions

▶ PRODUCTS

- 45 Single Scissors
- 46 Horizontal Double Scissor
- 47 Vertical Double, Triple and Quattro Scissor
- 48 Lorry Loaders
- 49 Low Profile Lift Tables
- 50 Armlifts
- 51 Tilt tables for table and floor mounting
- 53 Pallet lifter
- 54 Lift table accessories
- 60 PL 2002 - Pallet positioner
- 61 Pallet Buddy - Pallet magazine
- 64 Lift trolleys
- 65 Work Positioners
- 75 Lifting solutions in stainless steel
- 82 Movexx Electric Tuggers
- 84 Wheel lifters
- 85 AIR - mobile work platform
- 86 Goods lift
- 90 Terms of delivery





ERGONOMICS WITH LIFT AND TILT

When Volvo Personvagnar in Olofström built a new and revolutionary pressure hardening line for sheet metal components for the new Volvo XC90, EdmoLift were tasked with customising armlifts for material handling at the 3d laser cutting system. There are four armlifts at each laser cutting station and EdmoLift has delivered 32 armlifts in all to the factory.

The ALT 3000 armlifts have been substantially enlarged to be able to handle the large panels that are processed. The panels are used in the "safety cage" on the XC90 and are high strength so that they do not deform in a crash.

In order to achieve the best ergonomic results the armlifts combine lift and tilt in the same unit and also have a low height so that the operators need never to bend or stretch to pick up the material. The armlifts are also installed in pits and can be lowered completely down to floor level when not in use. This provides a free floor surface.



MAX 25 000 KG



DO NOT ENTER UNDER THIS PLATFORM
UNLESS IT IS MECHANICALLY LOCKED

НЕ ВХОДИТЬ ПОД ПЛАТФОРМУ
ПОКА НЕ БУДУТ ЗАКРЕПЛЕНЫ

Edmc Lift





TEST OPERATION FOR HITACHI

This lifting table can be found in Hitachi's newly built factory for excavators in Russia. The lifting table is used in order to be able to test drive the excavator caterpillar tracks under no load conditions.

Before the delivery, EdmoLift received a tough requirement specification containing a total of 250 points. For example, the lifting table had to be extra low and compact with its lowest height at 425 mm. Its capacity is as much as 25 tonnes, significantly higher than standard and the lifting table has four scissors.

It also features integrated measuring equipment with line sensors to avoid the risk of breakdowns. If it tilts over a specific limit, the lifting table begins to lower automatically.



NORRIPS GU UTRENDIG
NORRIPS GU UTRENDIG



MORE EFFICIENT PACKAGING

Norrlands Trä in Härnösand wanted to streamline its packaging station and at the same time create a more ergonomic and flexible work environment. Before the renovation, the operators had to bend down and sort part deliveries from finished wood bundles.

Now, EdmoLift has installed six TL 1000 lifting tables that are grouped into two groups of three. The lifting tables lift the wood stacks up to an ergonomically correct working height where they quickly can be taped for onward delivery.

The lifting tables have also customised electrical equipment so that they can either be synchronously operated in threes or individually, depending on the length of the wood, its weight etc.



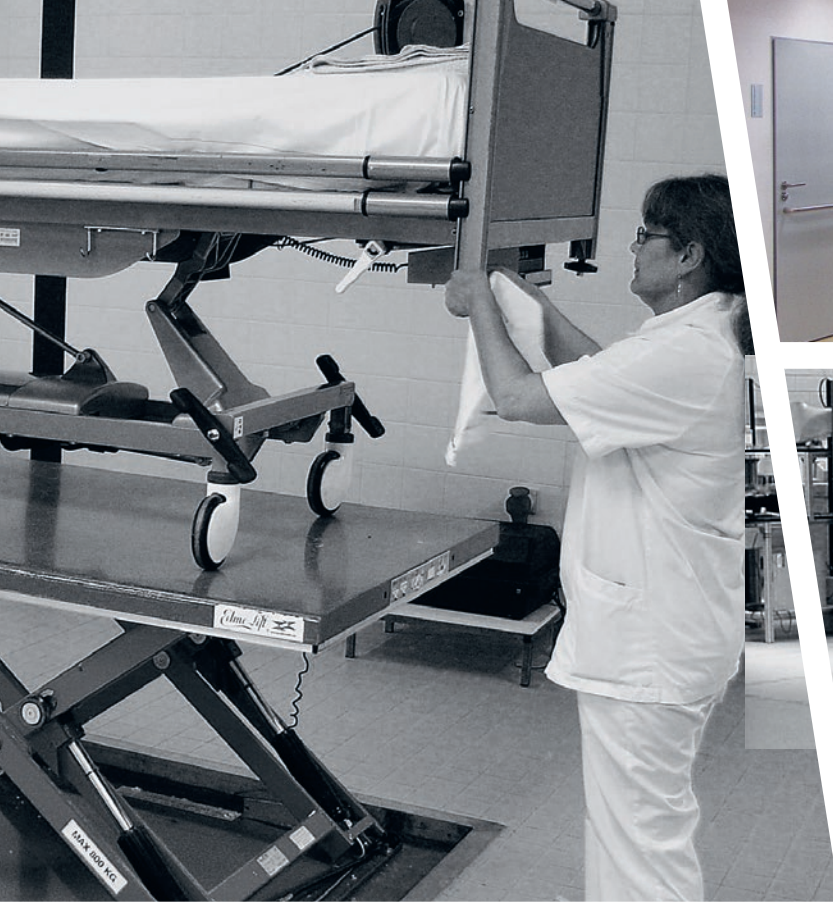

UNLIMITED LIFTING TECHNOLOGY

EdmoLift's technology has a huge number of areas of use, there are actually no limits to how and where it can be used. The need for lifting solutions in the industry is obvious, but there are also needs in many other contexts. Quite simply, EdmoLift can help you with a solution as soon as you have something or someone that needs to be lifted or lowered.

Welcome to our world of innovative solutions

FOR MORE THAN 50 YEARS, EdmoLift has supplied the world with ergonomic and efficient lifting tables. The highest quality has always been our strength, and approximately 100,000 of the 130,000 lifting tables we have manufactured are still in operation! We are very satisfied with that, and with the grades we get when we measure customer satisfaction, - 4.1 on a five-point scale.

WE ARE NOW WORKING systematically to increase the breadth of our range. We do this partly by developing new innovative solutions and partly by cooperating with new partners who complement our range. Our goal is for you as our customer to find what you want from us, no matter what your needs are.

WE ARE ALSO a company that takes clear responsibility for our planet. We are committed to minimising power consumption and use of undesirable substances. For example, six years ago we installed a powder coating facility that does not create any emissions (and also has a much better quality

paint finish). We also recover heat from both hardening oven and laser cutter and are thus self-sufficient in both heat and cooling.

WE CARE ABOUT people, both our own people, our customers' employees and people in the surrounding society. EdmoLift has just adopted a new value base which will form the foundation of everything we do. The three words that should lead us forward are *Enjoyment, Commitment and Respect*. Internally, the question is whether everyone feels job satisfaction. External that we should be a committed partner that shows respect for customers, suppliers and our planet. These are big words – of course – but what is important is that we have a consensus and work together to achieve our objectives. And we intend to do that for at least 50 years more.

WELCOME TO EDMOLIFT
– a world class global partner.

Anders Wahlqvist
CEO EDMOLIFT AB





"EDMOLIFT HAS SUPPLIED THE
WORLD WITH ERGONOMIC AND
EFFICIENT LIFTING TABLES FOR
MORE THAN 50 YEARS. THE
HIGHEST QUALITY HAS ALWAYS
BEEN OUR STRENGTH"



SMART LIFTING SOLUTIONS

EdmoLift is one of the world's largest manufacturers of scissor lift tables. For more than 50 years, we have worked at improving quality and developing our lift tables, pallet handling products and other equipment for material handling. Our goal is to be the supplier offering the most for the money on the market.

Made in Sweden



ARMLIFT WITH TILT



LIFTING TROLLEYS



DOUBLE SCISSOR LIFTING TABLES

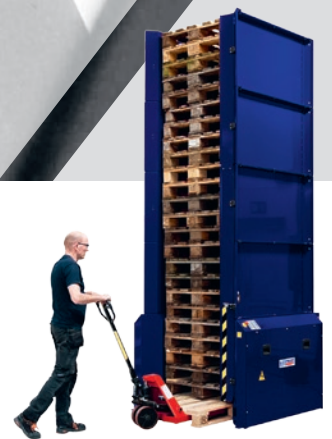

PALLET HANDLING

SMART LIFTING SOLUTIONS

EDMOLIFT

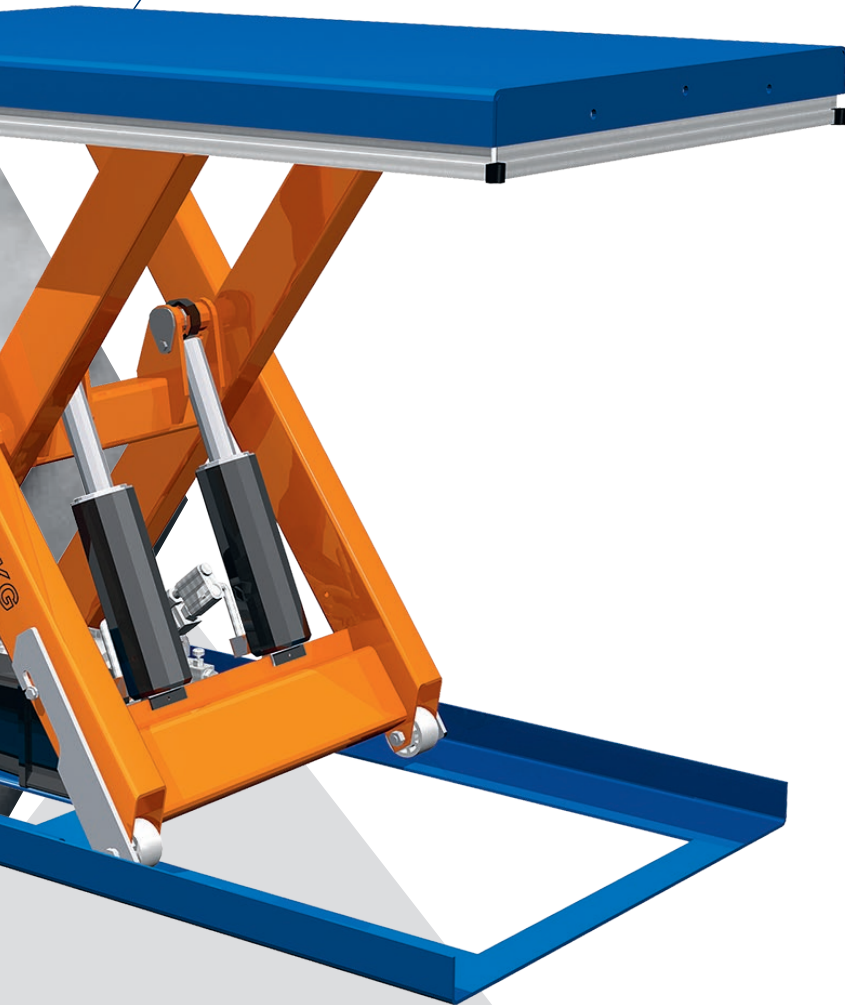

◀ **ERGONOMIC DESIGN**

Our goal is to get the materials as close to the operator as possible. That offers greater efficiency and healthier staff. We have over 50 years of experience with ergonomic production solutions.

◀ **INNOVATION**

Research and development has always been important to EdmoLift. The Armlift is world patented. Other innovations include the low profile lift table and UC60.

◀ **MADE IN SWEDEN**

Most of EdmoLift's products are produced and assembled in Sweden.

◀ **SPECIAL ADAPTATIONS**

Turntables on platforms, recesses in platforms, integrated scales, or guard rails and gates are some examples of special adaptations.

◀ **UC60**

Unique electronic control box which replaces 60 previous electrical devices. Plug-and-play with standard M12 connectors. Can be programmed to meet customer needs. UC60 is small and flexible, and replaces large electrical cabinets.

◀ **POWDER COATING**

Rock hard, scratch-resistant paint. Lasts much longer under normal use. Completely non toxic and emission-free.

◀ **OPTIONAL COLOUR FINISH**

All RAL colours can be selected, and also NCS colours.

◀ **WIDE RANGE**

Around 175 standard products and a range of accessories in order to be able to provide the correct offer to each and every customer.

◀ **HARD-WEARING TABLES**

Of 130,000 tables sold since 1964, approximately 100,000 are still in operation.

◀ **SPARE PARTS**

Original parts are held in stock and delivered quickly anywhere in the world.

◀ **SERVICE CONTRACTS**

A service contract will always guarantee you quick and professional service for your machines. Also included is regular maintenance, in order to increase machine life and minimise the risk of emergency stops.



LIFTS AND WORKING PLATFORMS



STAINLESS STEEL OPTIONS

Fifty years have taught us a lot about how good ergonomics improve productivity

WELL-THOUGHT THROUGH ERGONOMICS are not only good for the person using the machine but also for the company's efficiency and profit.

"Healthy people who are satisfied with their working environment do a much better job. Illness and injuries also cost money for the company in the form of such things as sickness benefit and the cost of training temporary replacements," says Mikael Fernlund, Nordic Countries Sales Manager at EdmoLift.

Since the start of EdmoLift, over fifty years ago, ergonomic solutions have been one of the fundamental pillars of the company's business concept. The very first lifting tables facilitated work for their users and reduced injuries and illnesses and their development has continued.

EDMOLIFT'S PATENTED ARMLIFT, which combines lift and tilt in the same unit, for example, yields large ergonomic benefits and is popular in the automotive industry. Some other examples of how lifting tables can be even more ergonomic are recesses in platforms and turntables in platforms.

"Our mission has always been to get the material as close to the operator as possible."

Employees should make as few unnecessary

movements as possible. That not only saves wear and tear on their bodies but also time and money.

Even light lifts can lead to strain injuries if they are repeated enough times.

"More and more customers are realising that there is a need for equipment for even light lifting, for example for foodstuffs in a shop or office materials in a storeroom. That's where our flexible Work Positioners work so well."

Sweden and Northern Europe are far ahead of the curve when it comes to ergonomics, but the rest of Europe and the world are now catching up quickly

EDMOLIFT IS WORKING CONSTANTLY at being at the forefront of development and being able to offer the best and most efficient ergonomic solutions.

"We believe that what is good for a man is good for productivity!"

GOOD ERGONOMICS

- ▶ INCREASES PRODUCTIVITY
- ▶ GIVES SATISFIED AND HAPPY EMPLOYEES
- ▶ SAVES SICK PAY
- ▶ MAKES YOU INTO AN ATTRACTIVE EMPLOYER

WORLDWIDE PATENT



WORLD PATENT ARMLIFT PROVIDES SUPERIOR WORKING POSITION

Our unique armlift offers lift and tilt in the same unit and has the world's lowest distance between floor and platform when in the folded position. Pallets and carts can be lifted directly from the floor by parallel arms.



Mikael Fernlund
Sales Manager
Nordic Countries

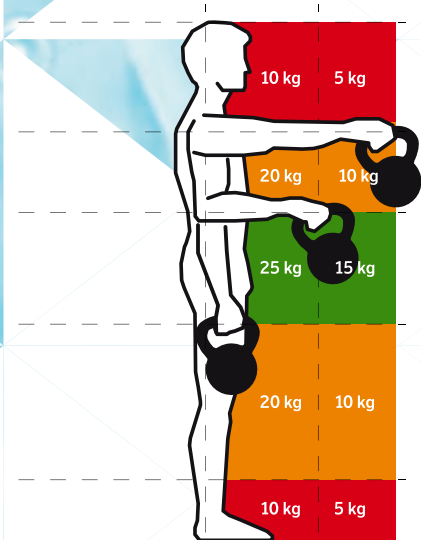

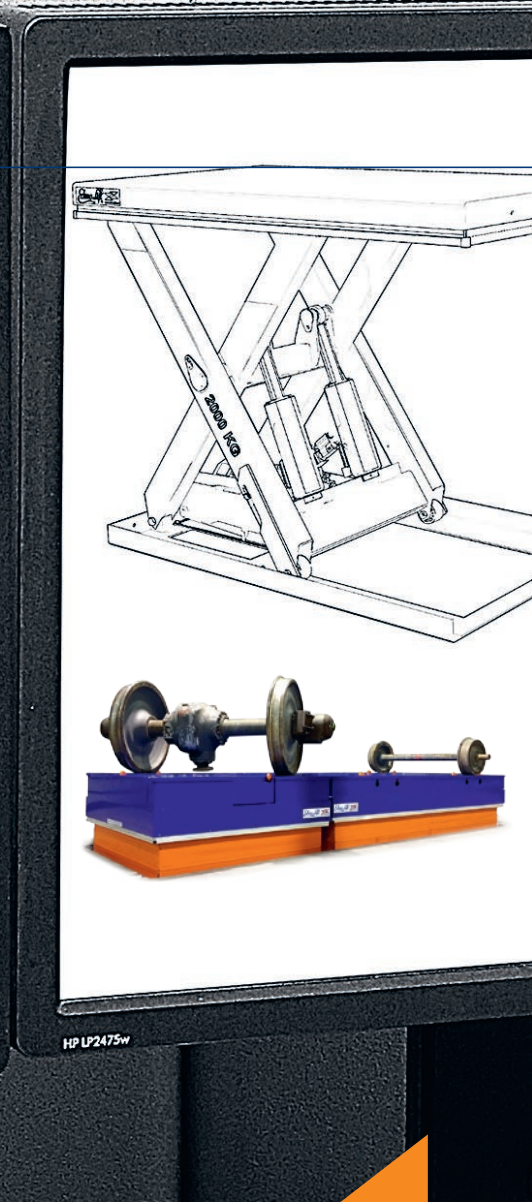
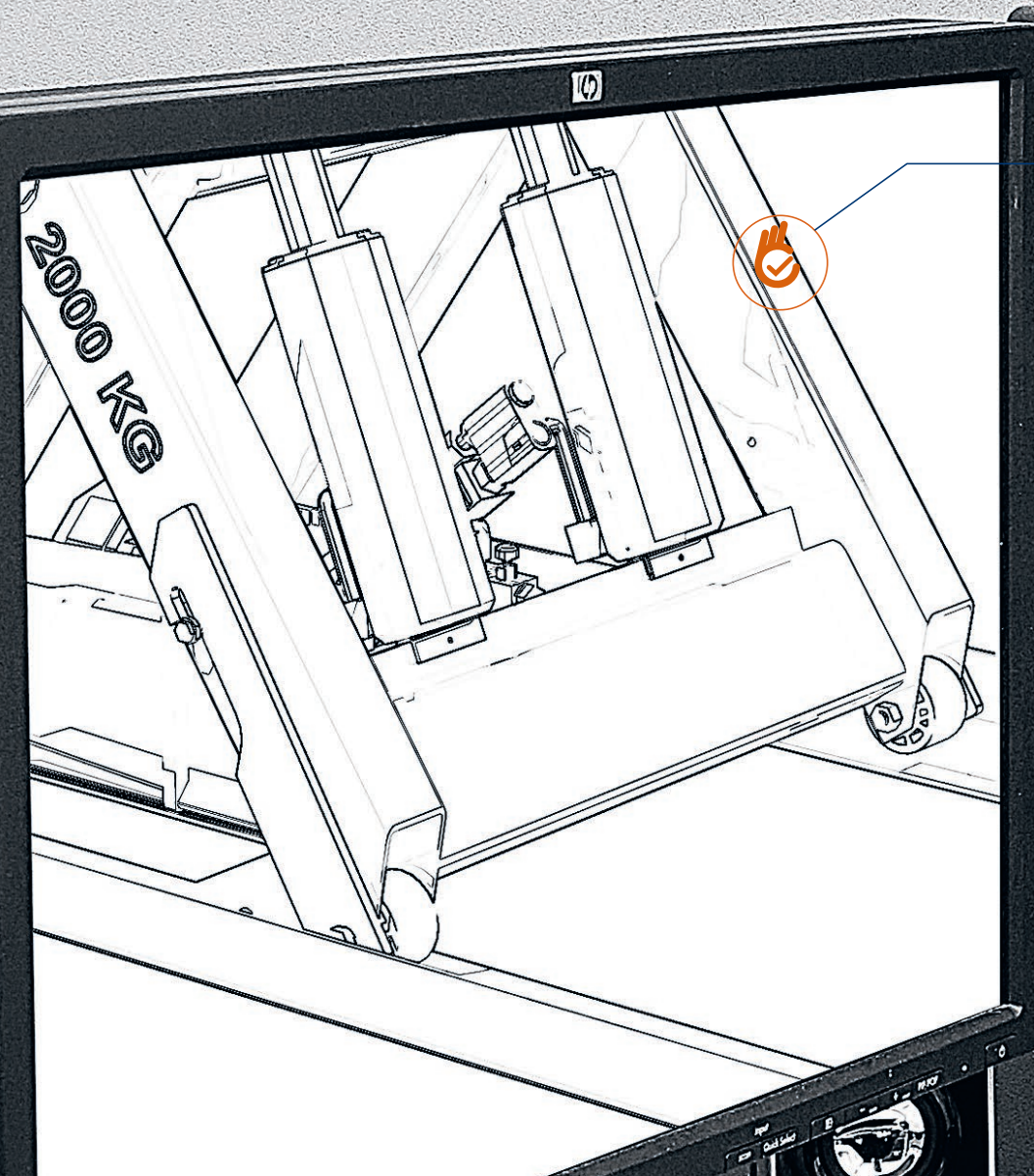

Customisation is our everyday task

TO GET THE MOST OUT of an investment you often require customisation. Sometimes, it can be a simple adjustment such as a larger than standard platform, a recess in the platform or a lifting table adapted to limitations on the company's premises. In other cases, more complex solutions are needed. Whatever the need, EdmoLift's design department stands ready to find the best solution that meets the customer's requirements.

MORE AND MORE CUSTOMERS are looking for solutions that are tailored to their activities. More than 40% of EdmoLift's sales consist of customised solutions. EdmoLift's workshop for customised lifting tables is now one of our most important departments.



SOME EXAMPLES OF SPECIAL ADAPTATIONS OF EDMOLIFT LIFTING TABLES:

- ▶ CUSTOMISED PLATFORM DIMENSIONS
- ▶ PLATFORM RECESSES
- ▶ ATTACHMENT WITH ROLLER CONVEYOR
- ▶ TURNTABLE ON PLATFORM
- ▶ ROLL-OFF GUARDS
- ▶ GUARD RAILS/GATES ON ONE OR MORE SIDES

◀ The design department's most difficult task so far:

Three large lifting table that were to work with train axles weighing up to 1.5 tonnes with a diameter of 1.2 metres. One thing was that they were very large tables and one of the tables had to have a recessed turntable.

Innovation is our watchword

RESEARCH AND DEVELOPMENT is a prioritised part of EdmoLift. At least 20% of the design department's time is devoted to new development. The ideas often come from the marketing department, which picks up on requests and needs when visiting customers. Customers' special requests are sometimes so good that they become new products or accessories to the standard range.

"WE HAD for example a customer who wanted to be able to weigh the goods on the lifting

table. We developed a solution with a truck handling chassis containing weighing cells. We developed it further and it is now a standard product in our range," says Head of design Hans Vikström.

"I THINK THAT we will see even more lift/tilt-solutions. We have just launched a new series of pallet lifters and we will develop our patented armlift further."

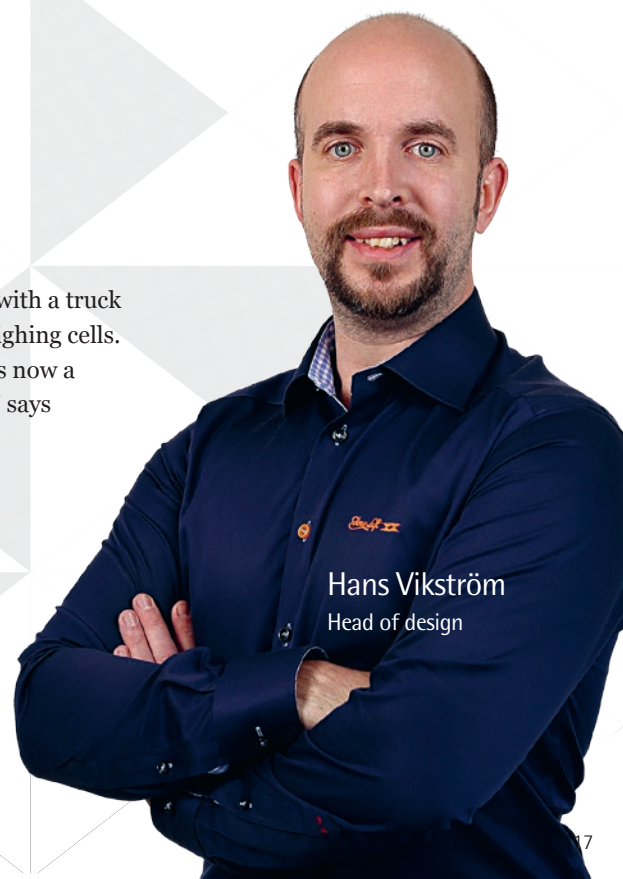

Hans Vikström
Head of design

UC60 is the brain in EdmoLift's lifting tables



UC60
Universal control that replaces 60 previous devices



EASIER
With one standard M12 connector you can connect virtually anything. No electrician needed



ECONOMIC
Replaces large wall cabinets or free-standing electric cabinets



CUSTOMISED
Can be programmed to meet customers' special needs.



DEVELOPABLE
Can be expanded to include new functions after purchase.

UC60 IS THE NAME OF THE small electronic control box that controls EdmoLift's products and replaces a total of 60 previous electrical devices.

"Our solution is unique in the industry," says Tobias Svensson, project manager.

The idea for the UC60 was hatched at the beginning of the twenty-first century, when customer needs gave rise to more and more advanced electronic devices. The choice to use M12 contacts was an obvious one in view of the large range of connectable components that were already on the market.

"Using the Plug-and-Play feature, each operator can easily connect equipment without having to engage a qualified electrician. This may be extra control units, sensors or other devices. The operator can even install desired functions, such as the upper and lower limit switches.

SINCE 2011, UC60 has been standard in EdmoLift's products and, in many cases, replaces large wall cabinets or free-standing electrical cabinets. Two models of UC60 are

available, standard and advanced. Both models have 15 program locations for standard designs and one program location dedicated to customer-specific solutions.

The advanced model has more inputs and outputs and also upgraded software that provides enhanced programming options. This meets the needs of those customers with a great deal of complexity in their use of peripheral equipment.

"We customise software and peripherals, based on the customer's needs. If a need is unique, a customer-unique program is delivered. But if the same need proves to be recurring, we add it as a standard program location.

ANOTHER HANDY feature is that the UC60 communicates with the operator using a buzzer that produces noises for various operations. In this way it is possible, for example, to get telephone support when accessories are installed. The customer can then often receive direct advice about what has to be done, without having to wait for a service technician.



UC60

Smart Lifting Solutions

ONE BOX, 60 SOLUTIONS

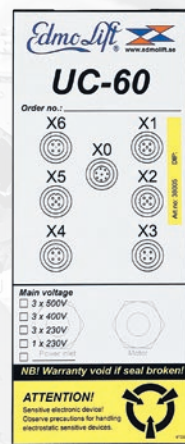

UC60 IS THE RESULT

of several years of development work to simplify the connection of the various devices to EdmoLift's products. UC60 makes it easy to install accessories, increases safety and simplifies servicing on the products. UC60 is equipped with M12 connectors and a wide range of plug-and-play devices are available.

Tobias Svensson
Project manager



Jan Eriksson
Quality and Environment manager

FR2000

EdmoLift is FR2000-registered - which means it has an integrated management system for Quality, Environment, Working environment, Fire protection and Skills.

EcoVadis

EdmoLift has achieved EcoVadis Gold level for its sustainability work in EcoVadis' CSR analysis (Corporate Social Responsibility). Thousands of companies around the world are analysed, about 5 percent of which reach Gold Level.



POWDER COATING FACILITY with completely non-toxic coatings and no emissions



LOW BAKE POWDER requires lower curing temperature, or shortens the curing time

Sustainable for the environment delivers hard-wearing lifting tables

WORKING WITH ENVIRONMENTAL ISSUES is inherent at EdmoLift. Its founder, Torbjörn Edmo, has always been interested in new energy solutions, both to reduce energy consumption and to save money. Today, heat is recovered equivalent to 120,000 kWh from the hardening oven and the laser cutter.

“We cover an area corresponding to 60 normal houses, but consume only the energy of four,” says Quality and Environment manager Jan Eriksson.

THE GREATEST ENVIRONMENTAL INVESTMENT in recent years has been the powder coating facility that is completely non-toxic and does not have any emissions. In addition, the quality becomes significantly better than that of the old wet paint system.

“Powder coating is extremely hard and scratch resistant and it has a high resistance to corrosion. Under normal use the coating lasts a very long time.”

EDMOLIFT WAS ONE OF the first in Sweden with low bake powder which reduces hardening times significantly, thus saving a lot of energy. The next step in the environment field is to reduce electricity consumption using power monitoring.

“We want to measure and analyse each process and optimise electricity consumption by starting, shutting down and using stand-by in exactly the right places.”

OTHER ENVIRONMENTAL MEASURES are that the pickling paste once used after welding stainless steel has been replaced by electronic cleansing and that the cleaning fluid used in the washing water change will be replaced by tablets.

“The environment and the economy really go hand in hand. There may be a substantial investment but the payback period is short once it gets going.”



RECYCLING of 120,000 kWh from the hardening oven and laser cutters for heating and cooling. The potential is for approximately 400,000 kWh

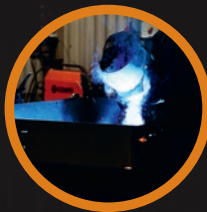

ELECTRONIC CLEANSING after welding stainless steel instead of pickling paste



POWER MONITORING to optimise electricity consumption



Lifting solutions for every need

EDMOLIFT HAS THE market's broadest range for material and pallet handling. There are large and small lifting tables, lifting trolleys, stainless steel options, tilts, pallet magazines and goods lifts.

"With the broad range we have, we can resolve almost any need that the customer can have. And sometimes we can see other possibilities and offer a variety of solutions. Or maybe a better solution than the customer originally envisaged," says Anders Wahlqvist, CEO of EdmoLift.

THE REQUIREMENTS VARY CONSIDERABLY between different sectors of industry. Large loads are often moved in the lumber industry, so that a lifting table with horizontal double scissors is the correct solution. In the classical engineering industry it is more often about pallet handling so that a standard single scissor lifting table or why not an armlift or a tilt gives better ergonomics.

"Then we have the industries that demand the highest standards of cleanliness, for example, the pharmaceutical, food and certain chemical industries. So we have the stainless steel options with a design that is easy to clean."

EdmoLift also develops solutions for new uses on markets outside the traditional industries, for example in the retail, service, distribution and transport sectors.

CURRENTLY, EDMOLIFT has approximately 175 standard products as well as a variety of accessories. Our objective is to broaden the range even more.

"Customers and dealers want as few suppliers as possible. That is why we are investing in an overall perspective and as wide a range as possible. We are going to have a solution to offer, regardless of what the need looks like.



LIFTING CAPACITY FROM 200 KG TO 10 TONNES



MODERN WORKING PLATFORMS



LIFTING TROLLEYS



STAINLESS STEEL FOR DEMANDING ENVIRONMENTS



ARMLIFT WITH TILT



PALLET MAGAZINE



LOW PROFILE LIFTING TABLES



LIFT HEIGHTS FROM 0.5-8 METRES



PLATFORM LENGTHS OF UP TO 7 METRES



**175 products
in 60 countries**



RAPID ASSISTANCE

– IF YOU NEED IT

WHEN YOU PURCHASE one of EdmoLift's products you can be confident that you will also get quick assistance and service when you need it. We have a well developed network of service partners in most countries.

OUR AIM IS for help to be as close to our customers as possible. Many of our service partners are also dealers and can therefore offer the entire chain from sales to installation and service.

IN MANY MARKETS we can offer service contracts with preventive maintenance and service. A good option is to sign a service contract when you buy a product from EdmoLift. This ensures that you get the best and quickest service in the event of sudden serious faults. But the important thing is that your machines get regular professional maintenance. In that way you avoid many unplanned stops and the product also has a significantly longer service life.

B2B SERVICE & SUPPORT

– RESPONSE WITHIN 24H

OVER MANY YEARS, EdmoLift has enhanced sales and support at its head office in Härnösand. A special group, B2B Service & Support, takes care of all the requests that come in, whether it is a question of quotations, order registrations, spare parts, failures during the warranty period or anything else. The Group has a single email address, b2b@edmolift.se. "Simpler questions get an answer within 24 hours, more complex questions within a maximum of 72 hours. But all of them get a direct confirmation that the question has been received by a personal

contact," says Erik Svanberg, manager for B2B Service & Support.

THE GROUP WORKS CLOSELY to spread expertise. The aim is for everyone to know more about everything. The new way of working was introduced in 2014 and the response from our customers has been good. Overall response times have been reduced since the new organisation was introduced.

"Good service is not only good for our customers but also for us. Having a close relationship with customers gives us valuable input for our product development.

RAPID SERVICE ANYWHERE IN THE WORLD

EdmoLift has service partners in many of the more than 60 countries in which the products are sold and can thus provide support to multinational companies. Many dealers have the most common spare parts in stock. Other spare parts can be delivered quickly from Härnösand to anywhere in the world.



Erik Svanberg
B2B Service & Support
Manager

B2B SERVICE & SUPPORT

- ▶ Handles all types of questions
- ▶ The customer receives a direct response that the question has been received
- ▶ Simpler questions are answered within 24 hours
- ▶ Customers receive a reply within a maximum of 72 hours
- ▶ Customers always receive answers from a responsible person
- ▶ Has a single email address: b2b@edmolift.se

www.edmolift.com

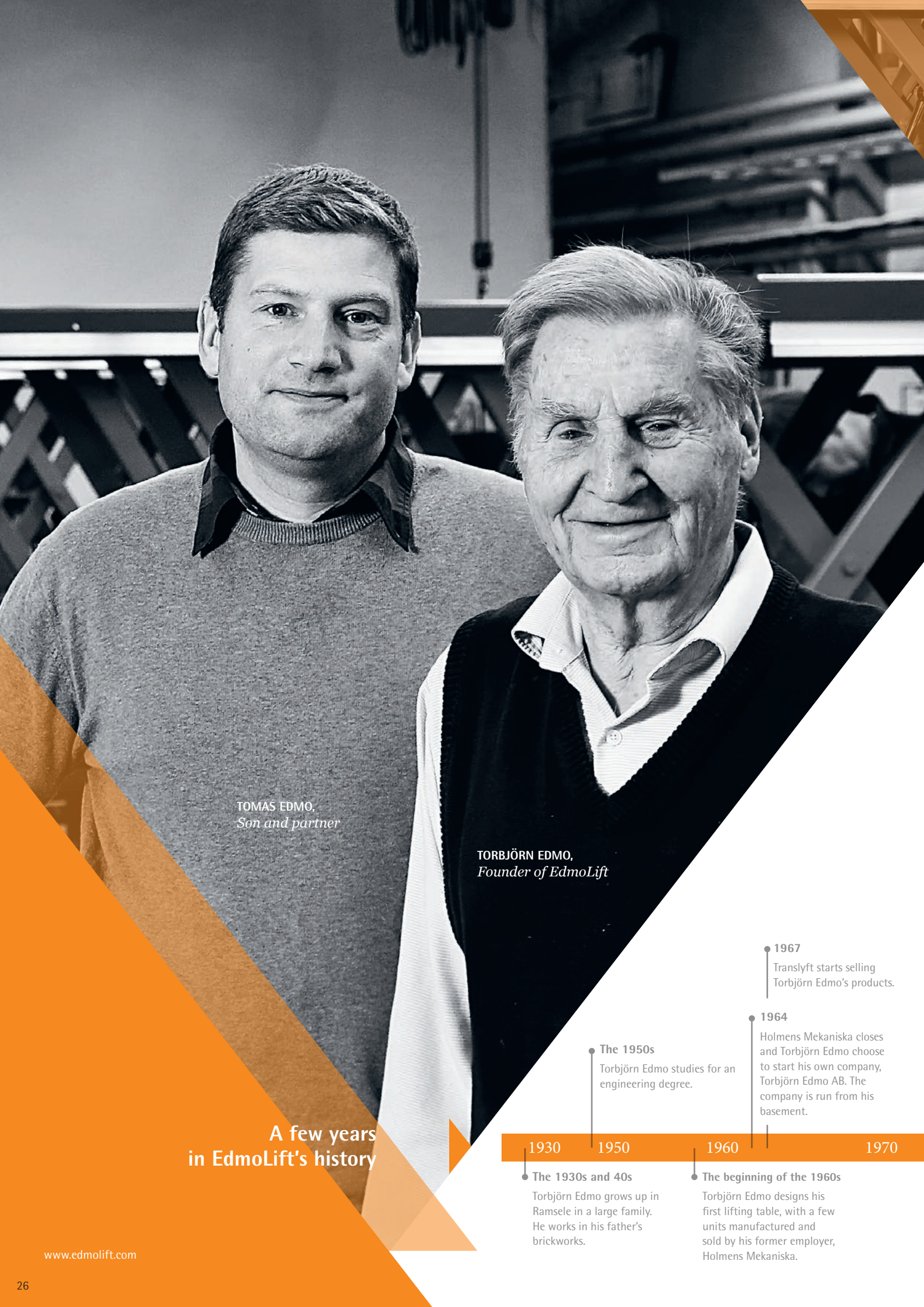

TOMAS EDMO,
Son and partner

TORBJÖRN EDMO,
Founder of EdmoLift

A few years in EdmoLift's history

- 1930
The 1930s and 40s
Torbjörn Edmo grows up in Ramsle in a large family. He works in his father's brickworks.
- The 1950s
Torbjörn Edmo studies for an engineering degree.
- 1964
Holmens Mekaniska closes and Torbjörn Edmo choose to start his own company, Torbjörn Edmo AB. The company is run from his basement.
- 1967
Translyft starts selling Torbjörn Edmo's products.
- The beginning of the 1960s
Torbjörn Edmo designs his first lifting table, with a few units manufactured and sold by his former employer, Holmens Mekaniska.
- 1970



A SMART LIFT ON EVERY SINGLE LORRY

In the 1970s, Torbjörn Edmo was design manager for the company Z-Lyften in Bispgården. This is where he developed the revolutionary hydraulic tail lift which today is called ZEPRO and is located, in principle, on all lorries around the world.

A journey through time with EdmoLift

EDMOLIFT IS BUILT around ingenuity and creativity. Torbjörn Edmo has always been inventive and started early by repairing and tweaking the machines in his father's brickworks. Later, while an employee of Holmens Mekaniska in Härnösand, he became interested in hydraulics and drew his first lifting table. When the company closed down he decided to start his own business.

"Actually, I never really liked being an employee. I preferred trying something and failing than not trying. That's just how I am."

THAT WAS THE BEGINNING of a long and exciting journey. More than 50 years later, EdmoLift is one of the world's leading manufacturers of lifting tables and has sold approximately 130,000 tables in 60 different countries.

BUT A LOT HAS happened in between, not just at EdmoLift. During the 1970s, Torbjörn Edmo

was design manager for the company Z-Lyften in Bispgården and developed the hydraulic tail lift (today ZEPRO). But instead of being paid by the hour he received a royalty per unit sold.

In principle, I worked unpaid at Z-Lyften at the beginning. If I had been paid the hourly rate as a consultant, the company had not existed today. More people should be able to do that sort of thing.

INGENUITY HAS SINCE been present throughout EdmoLift's history, where Torbjörn has been a leading force in the development of new products such as the low profile lifting table and the armlift range. He has also been a driving force in EdmoLift's environmental work, not least when it comes to the clever energy-saving measures.

In 1997, he handed over the post of CEO to Anders Wahlqvist so as to be able to spend more time in inventing and designing. "It is more fun than heading the company."

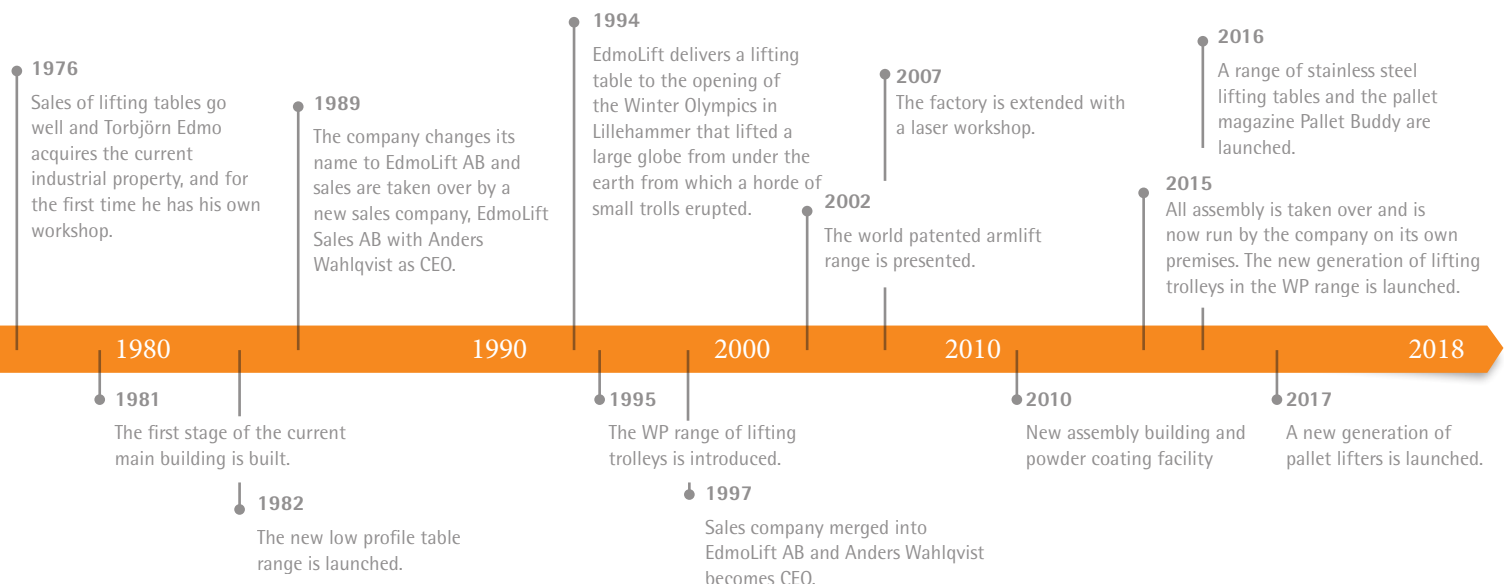



THE VERY FIRST LIFTING TABLES were constructed by Torbjörn Edmo at the beginning of the 1960s, when he was employed at Holmens Mekaniska in Härnösand. When the company closed, he took his ideas with him and started Torbjörn Edmo AB in 1964.

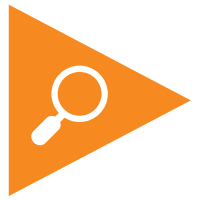

EDMOLIFT **GUIDE**

CHOOSE THE RIGHT LIFTING SOLUTION

www.edmolift.com



WHAT IS A LIFT TABLE?



In its simplest form, a lift table is a platform that can be raised or lowered to any height desired. The lift table can be placed directly on the floor, but can also be installed in a pit. To make the lift table more mobile there are accessories available like wheel and truck handling chassis.

THE BASIC PARTS OF A LIFT TABLE

The base frame

The base frame supports the lift table and serves as the chassis for the pair of wheels below. One side of the scissor is anchored in the back edge of the base frame, the so-called fixed side.

The scissor

The scissor supports the platform and gives it its vertical movement. The two scissor pairs are linked together by shafts through the centre. The scissor is fixed in the back edge of the platform and base frame, the so-called fixed side.

The platform

The size of the platform can vary in size as long as it is compatible with the base frame and scissor. It can be larger, but not smaller, than the length or width of the scissor/base frame. Platforms can be furnished with a number of different accessories such as conveyor platforms, turntables or fixtures to adapt the lifting table for the best ergonomics and work situation.

BENEFITS FOR THE COMPANY OF A LIFT TABLE FROM EDMOLIFT

Throughout industry there is a continuing need for the handling of materials. By using a lift table, productivity can increase and work injuries minimised. Both heavy and

light lifting can result in back or repetitive strain injuries. Lift tables are the ideal solution for lifting and positioning materials.



THE MANY BENEFITS OF A LIFT TABLE FROM EDMOLIFT

THE ERGONOMIC BENEFIT

An ergonomically correct workplace increases productivity and reduces the costs of staff who are injured at work and the costs of training new staff. The risks of bureaucratic sanctions because the company has not complied with the regulations for manual goods handle reduce.

SMOOTH ADJUSTMENT

A lift table is designed to be smoothly raised or lowered to the desired level. The situation is also maintained even in the event of a power failure.

VERSATILITY

A lift table can be complemented with a number of accessories such as conveyors platforms, tilting platforms, welding tables or special fixturing.

PROGRAMMABLE MOVEMENT

The lift tables movement can be programmed and integrated into customized systems.

PORTABILITY

The lift table can be fitted with accessories for increased applications. The wheel chassis makes the lift table directly movable and, for access to the pallet trolley or forklift truck, the truck handling chassis is used.

WIDE VERTICAL RANGE

The lift table can be placed on a floor or installed in a pit. There is also a low profile lift table that allows loading and unloading with pallet trolleys directly from floor level (U-shaped table) or with the aid of a ramp (low profile table with rectangular platform). For high lift elevations vertical double or triple scissors can be used.

MINIMAL MAINTENANCE

Lift tables are rugged, heavy-duty machines designed to provide years of reliable service with minimum maintenance.

STABLE PLATFORM

Unlike hoists, cranes or manipulators, lift tables provide a stable platform for lifting and lowering materials. The chance of accidentally dropping material is much lower. Nor will the goods ever swing with the risk of causing damage to the surroundings or injuries to staff.

EASY RETURN ON INVESTMENT

The economic lifespan of a lift table is in usual use at least 10 years.

Example:

Investment	25,000 SEK
Calculated depreciation	10 years
Estimated cost/year	2,500 SEK/year

With an hourly rate of 250 SEK/hour an increased efficiency of 2.5 minutes per 8-hour working day is required for return on investment.

EDMOLIFT LIFT TABLE MODELS



Single scissor lift table Our largest product group is made up of simple, yet powerful and versatile lift tables. These single scissor lift tables can be found in a host of different operations, all equally adaptable, stable and ergonomic in design. Lifting tables are often used as a means for materials handling directly on the factory floor or as a lorry loader outdoors on a loading dock. With a variety of performances and models, not to mention a load capacity of between 500 kilos and 10 tons, there is a lift table for every need. All T models can be customized to the end-users specific specifications. Lift tables are available in a variety of colours, with a range of accessories and control options, depending on your needs and preferences. A number of models can be of the heavy-duty variety suitable for use in intensive operations. It is also possible to increase functionality with the help of a number of accessories such as the wheel chassis, loadflaps, guard rails, roller conveyors and turntables. Before deciding which lift table and design is required, consider all occasions.

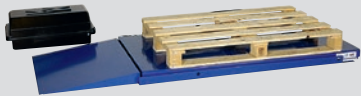

Low profile lift table Lift tables are built so low that installation in a pit can be avoided. The lift table is placed directly on the floor and is raised to working height. With a ramp (option) it is possible to drive up a pallet trolley onto the platform, which gives great flexibility. With E-shaped platform (TUB) or U-shaped platform (TUL) a pallet can be easily lifted on with the pallet trolley without a ramp. The lift table is controlled with a control unit connected to the external hydraulic power pack.



Horizontal double scissor lift table Horizontal double scissor tables consists of two mechanically synchronised scissors adjacent to each other and make it possible to lift heavy and long goods.



Vertical double, triple and quattro scissor lift table Vertical scissor lift tables are made up of two, three or four scissors on top of each other. Suitable when goods are to be lifted to a high level.



Armlifts The armlift both lifts and tilts and makes it easy to get the goods into the best and most comfortable position. Armlifts are the best choice when it comes to working with components on pallets, in boxes or baskets. Both lift movement and angular movement are available in the product's design, making armlift an economical alternative when the work requires lifting and tilt functions.



Scissor lift trolleys Swedish manufactured trolleys and working tables. From 200 kg to 1,000 kg loads.



Pallet lifters Pallet lifters provide free leg and foot space from three sides, giving superior accessibility and enables smooth working.



Tilts for table and floor mounting EdmoLift offers a complete tilt programme with many different tilt combinations.

More EdmoLift products

EdmoLift also has other lifting products which are presented further down in the handbook / lift trolleys (Work Positioners), pallet magazines, goods lifts and working platforms.

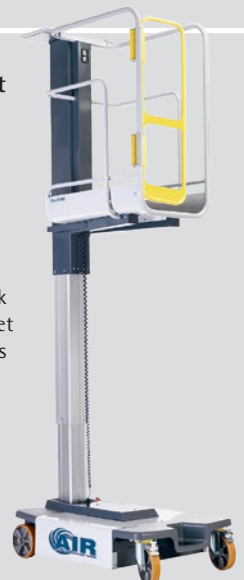

LIFT TABLE THE RIGHT CHOICE FOR MINIMISED RISK OF INJURY

Manual lifting can often give rise to fatigue and injuries to the back and shoulders for the operator. A lift table placed at the machine means that injurious lifting is prevented.



CHECKLIST FOR EFFECTIVE HANDLING OF MATERIALS

LOADING AND UNLOADING MATERIALS FROM MACHINERY

Loading and unloading materials from a machine is a process that often requires much lifting and positioning of the workpiece. Lifting can easily rob valuable production time because it takes time to move the materials. Manual lifting can often give rise to fatigue and injuries to the back and shoulders of the operator. Besides the personal suffering such injuries result in they also cost the company a lot of money in the form of for example sicklisting and substitutes. In the case of careless handling lifting can give rise to damage to the materials. A lift table placed at the machine means that injurious lifting is prevented.

HANDLING OF LONG GOODS

Long goods are difficult to manage and increase the risk of injury to employees who are in the vicinity. The goods can create problems during moving, positioning and storage. This even applies to goods that are not heavy. A horizontal double scissor lift table can also handle the longest materials easily and safely.

LOADING AND UNLOADING PALLETS

Bending, stretching is often tiring and gives rise to loading injuries to the back, neck and shoulders. Using lifting tables for loading and unloading of goods on pallets means that many harmful work positions can be avoided. The operator adjusts the lift table as desired. By using a turntable on the lift table the operator can rotate the pallet so that goods come into the best position.

LOADING AND UNLOADING GOODS FROM CAGES/ GITTER BOXES

Handling of goods in cages can give rise to the same type of loading injuries as working with pallets. The work is often monotonous which increases the risk of repetitive strain injuries. By using a lift table that both lifts and tilts the operator can reach the goods in an ergonomic way. Edmolift's Armlift programme is produced to give the operator the best ergonomics.

ASSEMBLY WORKPLACES

Many assembly operations take place with lightweight components, but with many repetitions. An example of this is the electronics industry. The assembler must also perhaps bend and stretch to access and see during the assembly. Many repetitions and uncomfortable work positions can give repetitive strain injuries. With a height-adjustable workstation where the assembly piece always reaches the right position, the risk of injuries is minimized.

TRANSPORTATION OF GOODS

If trolleys are used to transport goods to and between workplaces it is often required that the goods are lifted up to the workplace, machine and/or down from shelves in the materials storage. This lifting can both give rise to damage to materials and goods as well as repetitive strain injuries. By using a lift trolley, that combines lift functions with wheeled transportation, such injuries can largely be reduced.

HANDLING OF BULKY GOODS

In the case of handling bulky goods two people are often required who work in unfavourable working positions. With a lift table one person manages the job while the risk of lift injuries is minimized.

WORKING OFF THE GROUND

Climbing ladders and scaffolding to paint, weld, carry out installation work or even just to reach materials always risks accidents. The risk of falling or dropping tools on other employees is high. A lift table safely and efficiently takes people, tools and parts to the desired height. For such purposes a lifting table must be fitted with guard rail, kick board and carry a sign showing that the operator can be carried.

HOW TO CHOOSE THE RIGHT LIFT TABLE

EDMOLIFT HAS LIFT TABLES FOR ALL CONDITIONS

Lift tables are used for various tasks and in many areas and it is difficult to produce a lift table in standard design for all types of use. EdmoLift has a very wide range of lift tables and accessories which makes it possible to find combinations that are suitable for most conditions.

Lift tables are of standard design fitted for good and prolonged function in "normal" operation. In intensive driving with heavy loads, fast speed, tough environment, and perhaps more shifts requires that the lift table sometimes is oversized and HD-equipped. The lift tables electrical equipment is delivered as standard in protection class IP54. Tables for outdoor use must be fitted with anti-slip protection such as a tear plate, in accordance with the safety standards.

Maximum load = distributed load

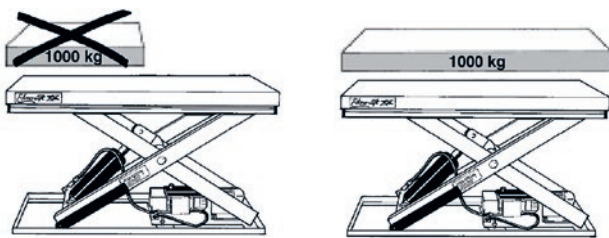

IMPORTANT ASPECTS WHEN SELECTING LIFT MODEL AND PERFORMANCE

Here are the prerequisites that you should take into consideration when choosing a lift table.

LOADING

Maximum load, weight distribution, bumps and knocks, twisting or side loading, point loading, distributed load, driving over with forklift trucks or lorries, the direction of movement of the load on roller conveyor

INTENSITY

The speed, how often the lift table will move, how many intervals, how many lifting movements/year, automated operation of system

PRECISION

Limit switch, upper-lower, precise stop is required, it is required that the lift table should remain in the exact position for a long time.

ENVIRONMENT

Outdoor installation, pit mounting, moisture, cold, dust, heat, chemicals, regulatory requirements

SAFETY

Risk of explosion, emergency operation, anti-slip protection, roll-over risk, control options, risk of crushing

ERGONOMICS

Accessories can further enhance the workplace, such as tilting platform with load restraint or turntable

Type designations and lift capacity

The type designations and lift capacity of EdmoLift lift tables apply in accordance with the following examples:

- ▶ Single scissor TL 2000 = max. load 2,000 kg distributed load
- ▶ Vertical double scissor TLD 2000 = max. load 2,000 kg distributed load, double lift height
- ▶ Horizontal double scissor TLH 2000 = max. load 2,000 kg distributed load, double length of platform
- ▶ In intensive driving the lift table is HD-equipped
- ▶ EdmoLift lift tables meets all safety regulations for lifting table in Europe:
 - The EN 1570-1 standard
 - The Machinery Directive
 - The Low Voltage Directive
 - The EMC Directive 2004/108/EC
 - Safety of machinery - Electrical equipment of machines - General requirements EN-60204
- ▶ The lift tables electrical equipment is delivered as standard in protection class IP54. Tables for outdoor use must be fitted with anti-slip protection, such as a tear plate, in accordance with the safety regulations.



The CE label on EdmoLift's products indicates that the product is in compliance with applicable EU directives.

Heavy-Duty-equipped lift table for intensive driving

Lift tables are of standard design fitted for good and prolonged function in "normal" operation. In intensive driving with heavy loads, fast speed, tough environment and perhaps more shifts requires that the lift table sometimes is oversized and HD-equipped (Heavy-Duty).



Lift table fitted with guard rails, gate, loadflap and protective wire mesh.

PIT DRAWING AND SURFACE TREATMENT

INSTALLATION OF A LIFT TABLE IN A PIT

When a lifting table is installed in a pit, the pit should be constructed according to the illustration on the right.

B = Width of the platform
L = Length of the platform
H = Lowest height of the lift table

The pit's ballast material must at least meet the concrete classification C12/15.

The hydraulic power pack for lifting tables in an outdoor environment should, where possible, be externally located in a covered or indoor environment.

1. Pipe for incoming cables, 100 mm in diameter. The fixed side of the lift table, B1, placed against this edge.

2. Drainage holes where required. This the third section in the centre of the pit should be 80 mm lower than H.

3. L-shaped profile 100 x 100 mm to reinforce the pit edges.

The pit drawing is not designed for low profile lifting tables.

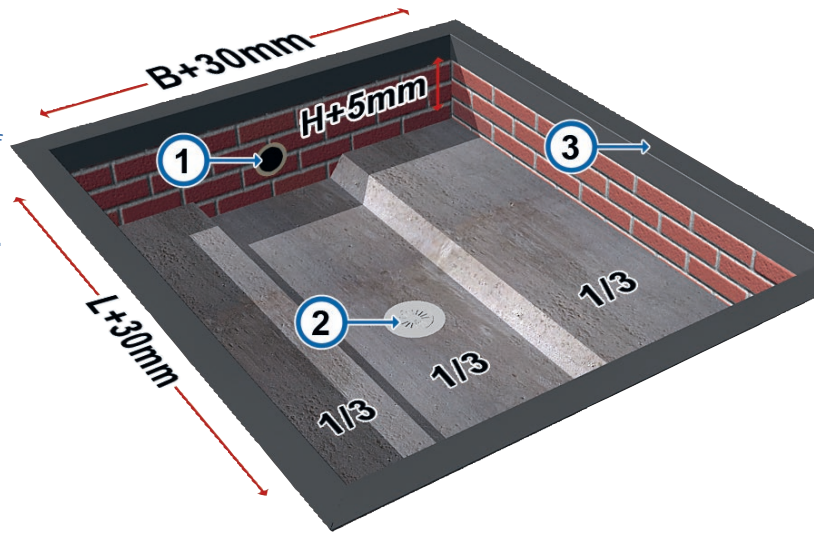

Fixed side of the lift table, B1

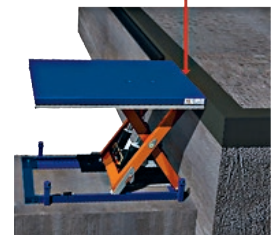

RECOMMENDED ACCESSORY FOR PLACEMENT IN A PIT

When a lifting table is installed in a pit, we recommend the following accessories:

- Upper limit switch (page 57)

- Lifting eye bolts (page 57)
- Mechanical stop (page 58)
- Inspection hatch in the platform (page 58), or external hydraulic power pack (page 57)

- If the lift table is to be placed in exposed or harsh environments, we recommend surface treatment with corrosion class C4 medium

SURFACE TREATMENTS THAT PROTECT YOUR LIFT TABLE

Products from EdmoLift can be delivered in a range of different RAL colours and finishes. Most of our products are powder coated in our own paint shop with a mixture of polyurethane and epoxy, which gives a surface with good wear and corrosion resistance.

CHOICE OF RAL COLOURS

Besides EdmoLift's standard colours we can also offer all RAL colours. If two colours are chosen they should interact.

ANTI-SLIP TEXTURED PAINT

If the platform is powder coated with textured paint, it takes on a sandpaper-like surface which provides excellent grip.

CORROSION PROTECTION

We offer powder coating with a primer that gives the product corrosion class C4 medium, in accordance with the standard SFS-EN ISO 12944-6. EdmoLift's products are delivered with corrosion class C3 medium as standard. Powder coated corrosion protection is greener, more economical and better looking than galvanized, at the same time as it may shorten the lead time by up to two weeks. We can also offer galvanisation if desired.



EdmoLift's standard colours (orange RAL 2010, blue RAL 5002, grey RAL 7024). In addition to these, EdmoLift offer more than 200 RAL colours. With textured paint the surface has a very good anti-slip protection.

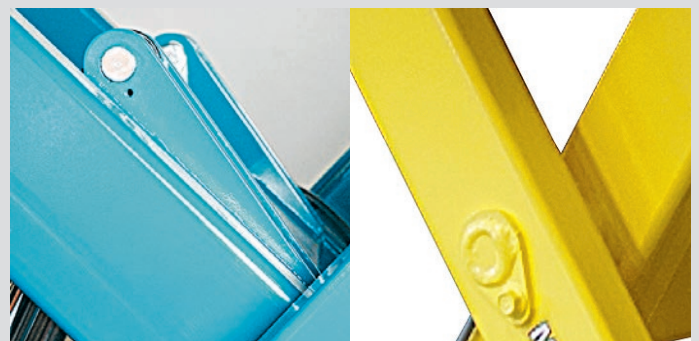

A powder coated surface is durable and provides very good corrosion protection.

UC60 – PLUG AND PLAY

COMPACT AND SIMPLE ELECTRICAL SYSTEM WITH PLUG AND PLAY FUNCTIONALITY

Our lift tables are fitted with the unique and proprietary electrical system UC60. For you as a customer this offers great benefits as you can easily retrofit our various accessories.

UC60 has M12 connectors and the built-in plug-and-play feature allows the operator himself, without hiring a qualified electrician, to plug in a wide range of accessories. Some examples of accessories that can be installed are extra control units, sensors and extension cables.

When installing accessories the control unit's built-in buzzer feedbacks to the operator to confirm that the installation was successful. In case of any problems the buzzer function makes it possible to obtain phone support where a technician from EdmoLift can hear the sound of what needs to be addressed.

STANDARDS

UC60 meets the following standards:

- EN 61000-6-2 (immunity)
- EN 61000-6-4:2007 EMC (radiation)
- 2014/30/EC
- EN 60204-1
- EN ISO 13850:2007

TECHNICAL DESCRIPTION

Standard operational voltages:

- 1 phase 230VAC, 3 phase 230VAC
- 3 phase 400VAC, 3 phase 500VAC
- Stabilised 24VDC, 60VA transformer

IP classification:

IP54, M12 connectors IP67

Dimension electric box: L:270 x H:85 x W:135 mm

EXAMPLE OF CONNECTIONS

- (standard lift table)
- X0 Control unit
- X1 Power pack valve / Hose burst valve
- X2 N/A
- X3 End limit switches
- X4 Passable limit switches
- X5 N/A
- X6 Safety frame + Hose burst valve



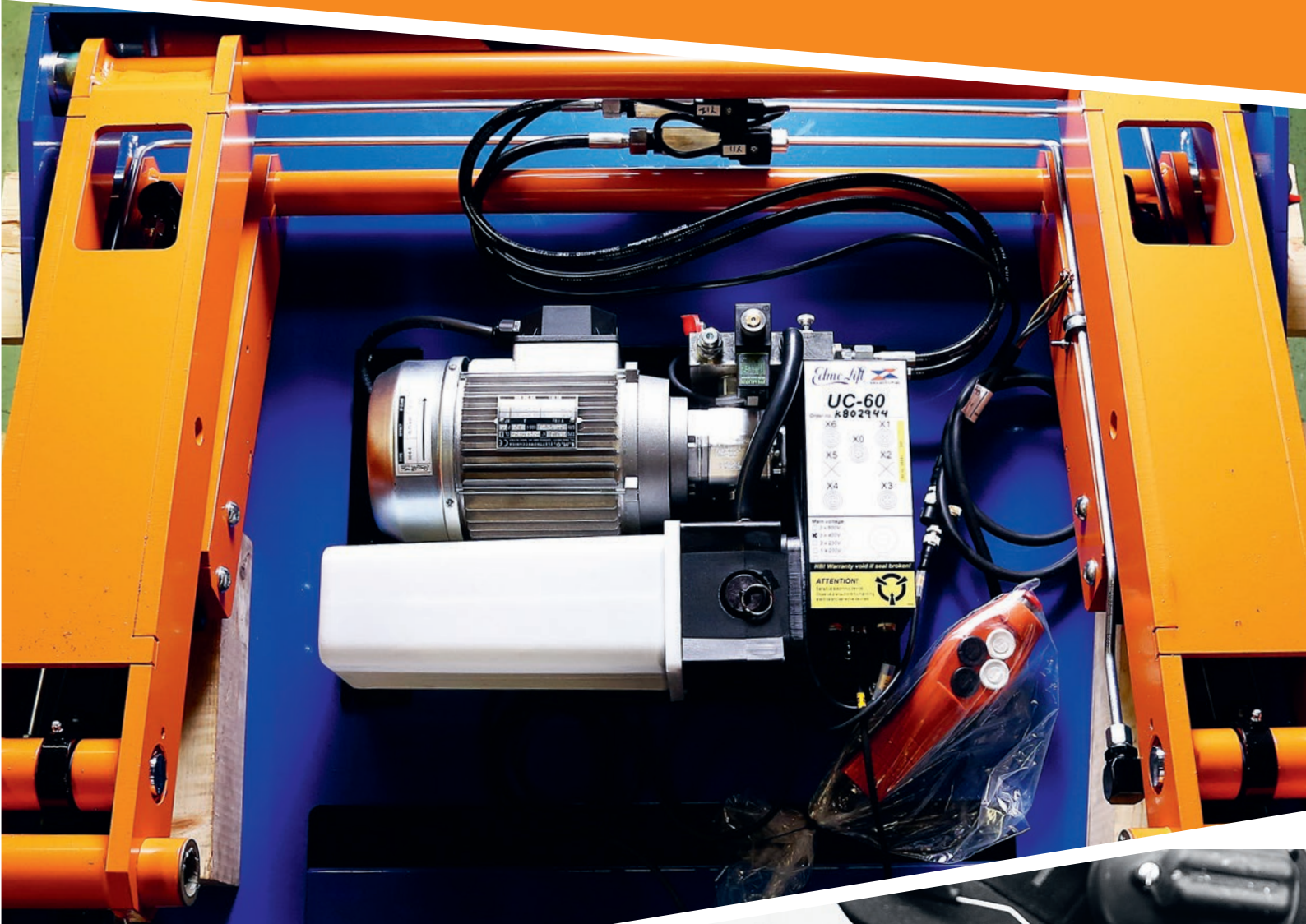

SAFETY REGULATIONS FOR LIFT TABLES

EDMOLIFT MEETS ALL SAFETY REQUIREMENTS FOR EUROPE

EdmoLift lift tables and pallet lifters meet all safety regulations for lift tables in Europe e.g. AFS 2012:2 in Sweden and the EN 1570-1-standard. The CE label on EdmoLift's products indicates that the product is in compliance with applicable EU directives. The lift table is as standard equipped with 400/24V low voltage 24V on the control unit, valve and switch for safety frame.

Built-in safety function in safety frame

If the safety frame is triggered when descending the lift table stops immediately. To continue lowering the lift table, it must be driven up a bit to activate descent. Lift tables are always supplied with a "deadman's switch" type of control unit.

This means that when the up or down button is released the platform stops immediately. The control unit is equipped with an emergency stop and lock.

During installation of the lifting equipment, the installer and employee must ensure that the risk of crushing cannot occur.

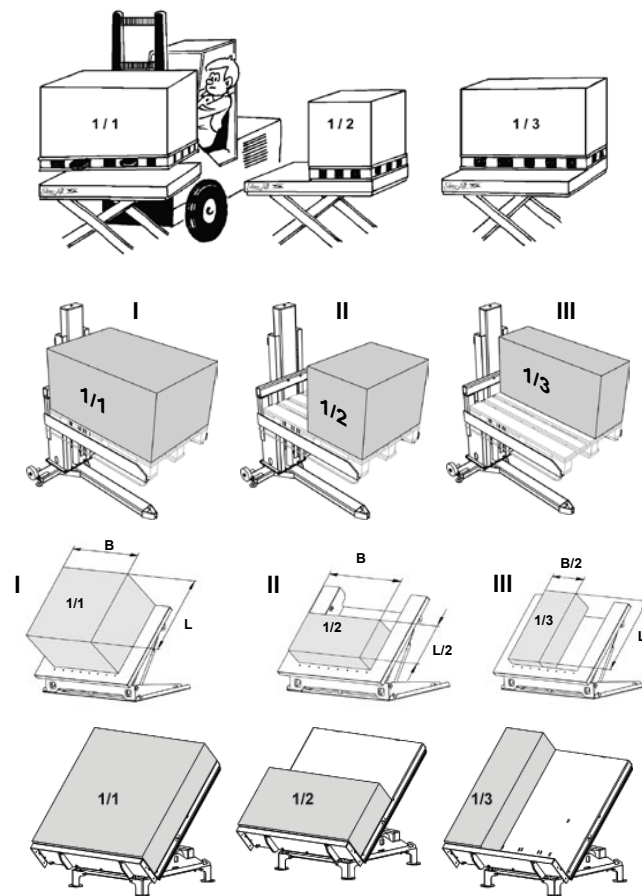

The stated lifting capacity of the lift table and pallet lifter required distributed load. TSL: Max. load = load centre 600 mm from column. NB! Lowering speed in accordance with standard max. 0.15 m/sec.

INTERNAL CONTROL OF THE WORKPLACE'S SAFETY

The employer is obligated to ensure that the equipment is used by competent staff and that control and maintenance of lifting equipment is carried out to the required extent.

Control and maintenance takes place in accordance with the Swedish Work Environment Authority's Statute Book: Internal control of loading ergonomics AFS2012:2 as well as that:

1. Maximum load of lifting equipment is not exceeded. The load is fixed and cannot roll off. **MAXIMUM LOAD = DISTRIBUTED LOAD!**

2. Function of safety frame and safety spacing around the equipment is checked.
3. Statutory warning labels are kept intact.
4. Any loading injuries are checked.
5. Cables and hoses are checked and maintained.
6. Oil leakage and possible further spread are checked. Lubricate where required.
7. Lift tables and pallet lifters are cleaned and serviced.
8. Main power switch is available to authorized staff. The lifting equipment must not be used by unauthorised persons.

9. The platform is fitted with roll-off guard for the transportation of wheeled loads or loads that could roll.
10. Tables for outdoor use are provided with anti-slip protection, such as tear plate, in accordance with the applicable safety standards.
11. Tilting table platforms are provided with load restraint for securing load.
12. That the required protective equipment, such as a guard rail, exist if a person besides the operator is included on the lift table.

13. Lift tables that are to be entered by persons equipped with anti-slip protection when there is a risk of slipping.
14. The carriage of passengers may therefore only take place in designated lift tables, see the lift tables signage.
15. No hands or feet are under the platform.



CE INSTRUCTIONS

All machines shall be provided with fully legible and indelible marking that includes at least the following information:

- CE mark or manufacturing declaration
- Serial number and type designation
- Year of manufacture
- IP class
- Category class

Preferably EdmoLift's standard machine signs should be used. They are individually made for each machine. If the machine is manufactured for use in potentially explosive environments (EX) this must be specified on the machine. The machine is also provided with all information that is relevant to the type of machine concerned and which is needed for it to be used in a safe way.

INTRODUCTION

User instructions provide complete information about the product, its installation, operation, care and maintenance as well as safety aspects for installation, use and dismantling. The instructions are written on EdmoLift's standard paper, in accordance with the instructions below. Basically, however, a handbook is generally included, which is supplemented as required. The authorised signatory of the EU Declaration of Conformity determines whether the handbook and any supplements are sufficient or not. When drafting new instructions based on standard products the Sales Department are contacted for support for the instructions.

USER MANUAL GENERAL

The product is described in those parts that are deemed essential for use, installation, maintenance and service. The description is as far as possible illustrated. The instructions also specify how the machine must not be used through the addition that all other use is not allowed without EdmoLift's permission. Furthermore, it is pointed out that modifications are also not allowed without permission.

GENERAL

An EU Declaration of Conformity has been drawn up for the machine, both for the larger machinery and safety components. The declaration is in the language of the user instructions and is accompanied by a translation

LOAD FACTORS FOR LIFT TABLES

	DYNAMIC FACTOR	HORIZONTAL LOAD COEFFICIENT (in % of rated load)	LIFETIME ^B minimum load cycles under full load (x10 ³)	INFORMATIVE EXAMPLE OF USE
1	1,4	10%	128 ^A	Lift tables for general use.
2	1,1	2,5%	8	Lift tables with a clearly defined lifting load and where other forces can be excluded; height adjustment without systematic lateral forces.
3	1,2	5,0%	32	Lift tables suitable for use in manual work, such as height-adjustable workstations.
4	1,3	10%	128	Lift tables suitable for driving over by e.g. forklift trucks or electric pallet stacker with a maximum braking force at 10%. Lift tables with unpowered roller belts.
5	1,4	10%	512	Lift tables suitable for a high number of lifting cycles.

When a vehicle crosses the lift table or the lift table is integrated in a management system, the lateral forces have to be verified in individual cases. Higher horizontal load coefficients have to be established if required.

^A This minimum number of cycles shall be increased by the manufacturer according to the purpose of use of the lift table.

^B When used (load cycle) according to lifting categories lifetime of lifting tables is generally 10 years when maintained in accordance with the manufacturers instructions.

into the language of the country where the machine will be used. The EU Declaration of Conformity is either typewritten or handwritten in capital letters. Attached under this tab is EdmoLift's standard form and authorisation for signatory of declaration of conformity or manufacturer's declaration.

MANUFACTURER DECLARATION

In cases where the machine will be part of a larger machine or installation, or if it is delivered incomplete, for example lacking control system, power pack or upper platform, instead of an EU Declaration of Conformity, a manufacturer's declaration is issued, that is a message that the machine must not be brought into service until the machine into which it will be incorporated has been declared to be in conformity with the provisions of this Directive.

The machine plate may not be provided with a CE mark.

EN 1570-1

EdmoLift lifting tables are designed and constructed to be safe, reliable and hard-wearing tools. In its basic version, EdmoLift lifting tables meet the basic requirements according to the lifting table standard EN 1570-1. This European Standard specifies the safety requirements for lifting tables that are used for lifting and/or lowering of material and/or trained persons accompanying the lifting table. The lift table must have two stop levels and may not pass in

between.

From the lifting tables standard EN 1570-1 (lift tables provide up to two fixed stop levels) the following points are particularly important:

5.1.2.4 The dynamic forces that are to be used for the calculations in accordance with 5.1.2.3 should at least consist of:

- the total vertical load (this includes maximum load and self-weight of the moving parts of the construction) increased by the dynamic factor for this lifting category in accordance with Table 2 as well as the horizontal load coefficient in accordance with Table 2, acting horizontally in platform level, in the direction causing the maximum stress to the part that is calculated.

If barriers prevent loading and unloading from one side of the platform or if the platform is otherwise blocked from moving in a direction, the horizontal load coefficient does not need to be considered in that direction.

5.1.2.5 If the platform is to be entered by operators, the weight of each person is assumed to amount to 80 kg distributed over an area of 0.2 x 0.2 m per person, with 0.5 m between each area's centre and placed in, from a the strength viewpoint, the most unfavourable position on the platform.

5.1.2.7.1 If the lift table is not designed for a specific load case, it must be designed for general loads in accordance with the basic requirements in the lift table

standard EN 1570-1:

- 100 % of maximum load uniformly distributed over the entire platform.
- or 50 % of load weight uniformly distributed over half of the platform area lengthwise.
- or 33 % of load weight uniformly distributed over half of the platform area sideways.

5.1.2.7.2 When the lift table is designed for a specific type of load case there should be a sign or instruction on the lift table which is clearly legible from the place of operation, displaying the intended load distribution.

5.1.3 Stability calculation

5.1.3.1 Lift tables must be stable (i.e. not be able to overturn) under all operating conditions, whether they are stationary or mobile.

The maximum permitted side force: 2.5-10% of the ground load, applied to the edge of the lift table.

Side forces occur, for example, when pressure is applied to the lifting table or the load by hand tools, or by pulling a tool or machinery part onto the platform. If the side force is applied to the load, the risk of tilting increases. Under no circumstances may risky tilting or downward bending occur when the lifting table is used in accordance with the manufacturer's instructions.

Side forces vary according to the above category table.

STYLISH LIFT TROLLEYS FOR PRODUCTION, OFFICE AND RETAIL

With our ergonomic lift trolleys, heavy and strenuous lifting is avoided which minimises the risk of work injuries caused by repeated lifting, moving and handling of heavy objects.



EDMOLIFT WP LIFTING TROLLEYS FOR WEIGHTS UP TO 300 KG

Work Positioners facilitate lifts and transport of goods in most industries. Our lifting trolleys are available in many different designs, with a wide range of accessories and options to customise them to meet your specific requirements. The lifting trolleys made of stainless steel and the industrial series can be specifically adapted to suit your particular needs.

COMMANDER SERIES – UP TO 90 KG

The Commander series stands out with its outstanding manoeuvrability, intuitive control unit and stylish appearance. The lifting trolleys in the Commander series effectively handles weights of up to 90 kg.

INDUSTRIAL SERIES – UP TO 200 KG

The lifting trolleys in the Industrial series effectively handle weights of up to 200 kg and are designed with the best ergonomics and flexibility in mind. The industrial series distinguishes itself with its versatile adaption options, the robust design and outstanding manoeuvrability.

STAINLESS STEEL SERIES – UP TO 300 KG

The lifting trolleys in the stainless steel series effectively handle weights of up to 300 kg and are designed with the best ergonomics and flexibility in mind.



MORE LIFTING SOLUTIONS FROM EDMOLIFT



PALLET BUDDY – AUTOMATIC PALLET MAGAZINE

PALLET BUDDY is a fully automatic up and down pallet stacking unit. You can stack and destack one pallet at a time efficiently and safely from ground level. PALLET BUDDY can also be used for pallet handling in cold storage rooms with temperatures down to -25 °C (accessory).

AIR – MOBILE WORK PLATFORM

AIR is a compact mobile work platform in a modern design.

AIR is easy to use, it rolls freely and easily passes through a standard doorway. This work platform works well in tight spaces and can lift a person with tools and load up to a maximum working height of 5 metres.



movexx
driven by brain power

ERGONOMIC ELECTRIC TUGGER

Electric tuggers makes it easy to move heavy loads on wheels. Whether you are moving trolleys, hospital beds, industrial carts, roll containers or other objects on wheels. With an electric tugger it can be done without any physical effort.



GOODS LIFT FOR INDOORS AND OUTDOORS USE

EdmoLift's goods lift is used to bridge the distance between different floors or mezzanines up to 7 500 mm. The goods lift has a strong design with a high lifting height and low minimum height which means that it does not need to be placed in a pit.

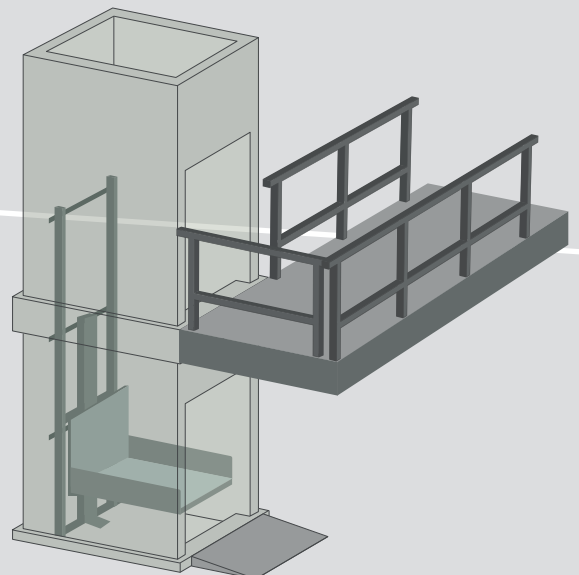



A REALLY HIGH LIFT TABLE FROM THE 1970S. Since then EdmoLift has developed the technique of lifting high even further with vertical double, triple and quattro scissors that can reach as high as 8 metres.

Lasercell 9



TruLaser Cell 8030



PRODUCTS 2018

Smart lift tables of the highest EdmoLift quality

LIFT TABLES FOR ALL CONDITIONS AND EXTENSIVE ACCESSORIES PROGRAMME



Handling of engine parts at a European car manufacturer.

The lift tables is the core of EdmoLift's business. It began in 1964 with the single scissor lift table and since this we have developed tables that match most needs. Here you can find for example horizontal double scissors for long and heavy loads, vertical scissors for high lifting, low profile lift tables for efficient pallet handling and lorry loaders. If you have additional needs we can customize your lifting table.

TWO PRODUCT SERIES – THE T AND C SERIES

Our lift tables and trolleys in the T-series are entirely Swedish-made and of the highest quality. As an example, the scissor arms on most lift tables in the T-series are made from KKR square bars in order to provide the very best lateral stability.

The models in the T-series can be adapted to meet your needs and are the best choice for demanding applications.

The C-series is our line of affordable lift tables that are made in China according to our designs, but are assembled and checked in our factory in Sweden.

The products in the C-series have Swedish-made electrical and hydraulic systems. C-series models come in standard sizes and can be equipped with a selection of accessories.

Model names beginning with the letter T belong to the T-series and those that start with C belong to the C-series.

STANDARD FOR ALL LIFT TABLES

- ▶ Lift capacities from 200 kg up to 10,000 kg
- ▶ Lift platform lengths from 900 mm to 7,000 mm
- ▶ Extensive accessories programme and options of customer-adapted lift tables
- ▶ Complies with the EU standard EN 1570-1 – CE labelled
- ▶ 24VDC control unit and control unit with deadman's switch
- ▶ IP54 approved electrical system
- ▶ Safety spacing between all moving parts
- ▶ Overload protection
- ▶ Adjustable trap prevention safety trip bars on all four sides of the platform
- ▶ The lift table is equipped with hose burst valves and mechanical locks for servicing and maintenance
- ▶ The lift table has maintenance-free bearing surface
- ▶ PLC control with ability to program the different functions included in the standard design
- ▶ User manual in 20 different languages

Single Scissors

Our largest product group, single scissors, is available in a range of designs, all equally flexible, stable and ergonomically well thought-out. Lift tables are commonly used as a means for handling materials directly on the factory floor or as a lorry loaders outdoors at a loading dock.

- ▶ T-model lift tables are Swedish-made and of the highest quality. They can be customized based on your own needs
- ▶ C-models are our affordable options and come in standard design with a range of accessories
- ▶ Special dimensions and other customizations can be quoted on request
- ▶ See page 75-81 for stainless alternatives



TL 2000

C-model	Art. no.	Capacity kg	Lift stroke mm	Lowest height mm	Length mm	Width mm	Lift time sec	kW	Weight kg pack. incl.	Note
▶ CR 500	36473	500	600	160	900	600	12	0,37	110	
CR 1000	515215	1000	600	160	900	700	23	0,37	130	
▶ CL 1001*	36045	1000	820	180	1200	800	15/26	0,75	180	
CL 1500	524827	1500	820	200	1300	1200	17	1,5	255	
▶ CL 2000	36474	2000	820	200	1300	800	17	1,5	250	
CL 2000B	613210	2000	820	200	1300	1000	17	1,5	264	
▶ CB 1200	524828	1200	1000	210	1500	1200	17	1,5	305	
▶ CB 1500	36475	1500	1000	210	1500	800	17	1,5	275	
▶ CB 1500B	36478	1500	1000	210	1500	1000	17	1,5	300	

*1-phase free of charge

T-model	Art. no.	Capacity kg	Lift stroke mm	Lowest height mm	Length mm	Width mm	Lift time sec	kW	Weight kg pack. incl.	Note
TR 501	609945	500	600	160	900	700	12	0,37	140	
TR 1002	608179	1000	600	160	900	700	22	0,37	145	
▶ TL 1000	34964	1000	820	180	1300	700	15	0,75	185	
TL 1000H**	613230	1000	930	180	1350	800	15	0,75	214	
▶ TL 1000B	32920	1000	820	180	1300	800	15	0,75	190	
▶ TL 1000XB	32925	1000	820	180	1300	1000	15	0,75	210	
TL 1001B	33024	1000	820	180	1200	800	15	0,75	180	
▶ TL 2000	22010	2000	820	200	1300	800	17	1,5	237	
▶ TL 2000B	22011	2000	820	200	1300	1000	17	1,5	249	
▶ TL 2000XB	512633	2000	820	200	1300	1200	17	1,5	275	
▶ TL 3000	33560	3000	820	250	1300	800	26	1,5	300	
▶ TB 2000	22253	2000	1000	220	1500	1000	26	1,5	260	
TB 2000B	22254	2000	1000	220	1500	1200	26	1,5	280	
▶ TM 1000	32970	1000	1100	180	1700	700	27	0,75	260	
▶ TM 1500	22012	1500	1100	230	1700	1000	17	1,5	311	
▶ TM 1500B	33145	1500	1100	230	1700	1200	17	1,5	337	
TM 3000	33180	3000	1100	250	1700	900	27	1,5	386	
TM 6000*	33810	6000	1100	300	1700	900	32	3,0	550	
TA 1000	33335	1000	1300	200	2000	800	16	1,5	300	
TA 2000	34230	2000	1300	230	2000	900	30	1,5	400	
TA 4000	33860	4000	1300	350	2000	1200	27	3,0	650	
TA 10000*	33240	10000	1100	600	2000	1100	40	4,0	1200	
▶ TS 2001	606524	2000	1500	250	2200	1200	27	1,5	542	
TS 2001B	610969	2000	1500	250	2200	1500	27	1,5	598	
TS 4000	33430	4000	1500	350	2200	1200	27	3,0	700	
TS 4000B	33440	4000	1500	350	2200	1500	27	3,0	770	
TT 3000	32662	3000	1700	300	2500	1300	27	3,0	705	
TT 6000	33460	6000	1600	450	2500	1300	40	3,0	1190	
TT 10000*	33070	10000	1500	600	2500	1300	55	4,0	1550	
TP 3000	514564	3000	2000	400	3000	1500	38	3,0	1160	
TP 6000	33400	6000	2000	500	3000	1500	55	3,0	1375	
TV 10000*	33200	10000	2200	700	3600	1500	72	4,0	2900	
TF 3000	34090	3000	3600	500	5000	2000	60	4,0	2300	
TF 4500*	606550	4500	3500	590	5000	2400	63	7,5	3100	
TO 4000	33840	4000	4000	600	5600	1500	95	4,0	2500	

*External hydraulic power pack excluding cover **Flat steel plate scissor arms

Horizontal Double Scissors

To handle goods that are both heavy and long you require a scissor lift table with special properties. The lift platform is equipped with a combination of two pairs of scissors to obtain the desired lift range and length of the lift table. Lift manoeuvres of the two pairs of scissors are mechanically synchronized to achieve a parallel lift operation. EdmoLift's horizontal double scissor lift tables make it possible to handle bulky goods in a safe and effective way.

- ▶ All models can be manufactured in the HD version for heavy duty operations
- ▶ Special dimensions and other customizations can be quoted upon request



TLH 4000

Model	Art. no.	Capacity kg	Lift stroke mm	Lowest height mm	Length mm	Width mm	Lift time sec	kW	Weight kg pack. incl.	Note
TLH 2000	32930	2000	820	180	2600	800	30	0,75	350	
TLH 4000	33115	4000	820	200	2600	800	35	1,5	450	
TBH 4000	603261	4000	1000	230	3000	1000	40	1,5	490	
TMH 3000	33147	3000	1100	230	3400	900	35	1,5	700	
TMH 6000	33176	6000	1100	250	3400	900	55	1,5	740	
TMH 10000*	33902	10000	1100	300	3400	900	64	3,0	1100	
TAH 2000	33885	2000	1300	200	4000	800	32	1,5	600	
TAH 4000	34395	4000	1300	230	4000	900	45	1,5	800	
TAH 8000	33890	8000	1300	350	4000	1200	53	3,0	1300	
TSH 4001	610970	4000	1500	250	4400	1200	55	1,5	1036	
TSH 8000	33495	8000	1500	350	4400	1200	53	3,0	1360	
TTH 6000	32885	6000	1700	300	5000	1300	53	3,0	1400	
TTH 10000	33600	10000	1600	450	5000	1300	75	3,0	2215	
TPH 6000*	516158	6000	2000	400	6000	1500	37	5,5	2100	
TPH 10000*	33555	10000	2000	500	6000	1500	72	4,0	3240	

*External hydraulic power pack excluding cover

Vertical Double, Triple and Quattro Scissors

By equipping a scissor lift table with a number of scissor arms assembled vertically on top of each other, the user gets access to a higher height range compared to what is possible with a single scissor lift table. EdmoLift's vertical double, triple and quattro scissor lift tables can, for example, be used as work tables, lifts for disabled people, freight lifts and car lifts, to name a few applications.

Compared with traditional lift solutions, EdmoLift's vertical double, triple and quattro scissor lift tables provide a rational and cost effective solution.

- ▶ T-model lift tables are Swedish-made and of the highest quality. They can be customized based on your own needs
- ▶ C-tables are our affordable options and come in standard design with a range of accessories
- ▶ Special dimensions and other customizations can be quoted upon request
- ▶ See page 75-81 for stainless alternatives



Goods and freight lift



Car lift at a exhibition hall



Double Scissor TLD 2000

C-model	Art. no.	Capacity kg	Lift stroke mm	Lowest height mm	Length mm	Width mm	Lift time sec	kW	Weight kg pack. incl.	Note
CRD 200	36472	200	1170	280	900	600	12	0,37	125	
CLD 1500	518584	1500	1420	360	1300	850	29	1,5	320	

T-model	Art. no.	Capacity kg	Lift stroke mm	Lowest height mm	Length mm	Width mm	Lift time sec	kW	Weight kg pack. incl.	Note
TRD 500	600330	500	1100	275	900	700	28	0,37	185	
TLD 1000	600613	1000	1600	320	1300	800	23	1,5	230	
TLD 1000XB	601741	1000	1600	320	1300	1000	23	1,5	250	
TLD 2000	22018	2000	1600	360	1300	800	34	1,5	325	
TLD 2000B	22015	2000	1600	360	1300	1000	34	1,5	345	
TLD 2000XB	524835	2000	1600	360	1300	1200	34	1,5	360	
TBD 2000	611320	2000	1800	360	1500	1000	34	1,5	425	
TMD 1500	22013	1500	2200	400	1700	1000	46	1,5	460	
TMD 3000*	33510	3000	2200	500	1700	900	50	3,0	580	
TAD 2000	611666	2000	2550	450	2000	900	59	1,5	630	
TSD 1500	33370	1500	3000	450	2200	1200	55	1,5	720	
TTD 3000	33670	3000	3300	600	2500	1300	60	3,0	1200	
TTD 5000	32893	5000	3200	700	2500	1500	83	3,0	1715	
TPD 3000	601319	3000	4000	700	3000	1500	80	3,0	2100	
TXD 4000	32976	4000	5300	900	4000	1500	100	4,0	2820	
TFD 4000	34948	4000	5900	980	5000	2400	155	5,5	3600	
TLT 1500	600851	1500	2400	500	1300	800	60	1,5	525	Triple Scissor
TMT 1500	22014	1500	3300	600	1700	1000	55	1,5	580	Triple Scissor
TST 2000	33780	2000	4500	700	2200	1200	80	3,0	1120	Triple Scissor
TPT 4000	604124	4000	6000	1000	3000	1500	104	5,5	2800	Triple Scissor
TSQ 1000	604738	1000	6000	1000	2200	1200	80	3,0	1500	Quattro Scissor

*External hydraulic power pack excluding cover

Lorry Loaders

EdmoLift's lorry loader is develop to be used on loading platforms for the unloading and loading of vehicles. The lorry loader evens out the difference in level between the vehicle and the permanent loading platform. The lorry loader is designed and equipped to handle the great stresses that result when vehicles and forklift trucks pass over the lift table.

- ▶ Lorry loaders with lift capacities of more than 2,000 kg can be quoted on request



Lorry loader installed in pit, fitted with guard rails, gates and protective wire mesh.



TTV 2

INCLUDED AS STANDARD

- ▶ Reinforced platform for driving over, two-tonnes wheel pressure
- ▶ Anti-slip platform in tear plate
- ▶ Control unit for outdoor use
- ▶ Mechanical adjustable stops in the base frame

EXAMPLES OF ACCESSORIES

- ▶ External hydraulic power pack
- ▶ Roll-off guard
- ▶ Inspection hatch
- ▶ Guard rails and gates
- ▶ Protective wire mesh, protective skirt and bellows
- ▶ Loadflaps that are hydraulic or manual

Model	Art. no.	Capacity kg	Lift stroke mm	Lowest height mm	Length mm	Width mm	Lift time sec	Lift time mm/sec	kW	Weight kg pack. incl.	Note
TTV 2	36292	2000	1700	302	2500	1600	27	63	3,0	890	
TTV 2B	36293	2000	1700	302	2500	2000	27	63	3,0	1000	
TTV 2LB	36294	2000	1700	302	3000	2000	27	63	3,0	1085	
TTV 2LXB	36295	2000	1700	302	3000	2400	27	63	3,0	1220	

Low profile U-shaped platform

EdmoLift low profile lift tables with U-shaped platforms are designed for rational pallet handling with a pallet truck. No loading ramp is needed.

- ▶ 1,000 kg tables with a lifting height of 970 mm are available on request
- ▶ The C-model is our affordable option
- ▶ See page 75-81 for stainless alternatives

- ▶ Width between forks
TUB 600 – 580 mm
TUL 1000, TUL 2000, CUB 1000 – 585 mm

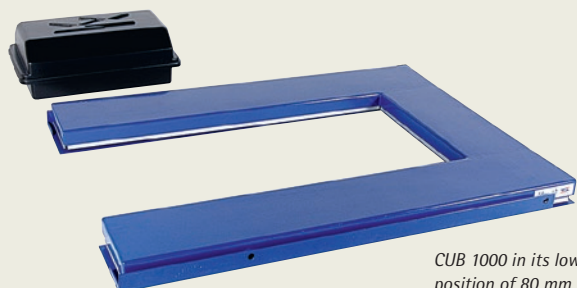

CUB 1000 in its lowest position of 80 mm.



CUB 1000

C-model	Art. no.	Capacity kg	Lift stroke mm	Lowest height mm	Length mm	Width mm	Lift time sec	kW	Weight kg pack. incl.	Note
▶ CUB 1000	34858	1000	720	80	1450	1085	13	0,75	240	

T-model	Art. no.	Capacity kg	Lift stroke mm	Lowest height mm	Length mm	Width mm	Lift time sec	kW	Weight kg pack. incl.	Note
TUB 600	33250	600	720	80	1450	900	13	0,75	250	
TUB 600H*	33255	600	970	80	1450	900	19	0,75	250	
▶ TUL 1000	601243	1000	820	80	1350	1080	13	0,75	240	
TUL 2000	601906	2000	820	100	1350	1180	24	0,75	350	

*TUB 600H must be secured to the floor by bolts or similar

Low Profile Lift Tables

EdmoLift's low profile lift tables feature a very low integration height, eliminating the need for an integration pit.

- ▶ 1,000 kg tables with a lifting height of 970 mm are available on request
- ▶ The C-models are our affordable option
- ▶ Access ramps are an accessory and are not included as standard
- ▶ See page 75-81 for stainless alternatives

CCB 1000 fitted with access ramp

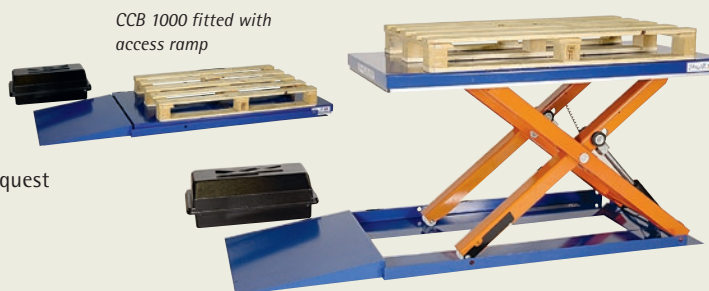

C-model	Art. no.	Capacity kg	Lift stroke mm	Lowest height mm	Length mm	Width mm	Lift time sec	kW	Weight kg pack. incl.	Note
CCB 1000*	34860	1000	720	80	1500	800	13	0,75	225	
CCB 1000B*	35395	1000	720	80	1500	1000	13	0,75	235	
CCB 1000XB*	524834	1000	720	80	1500	1200	13	0,75	310	

T-model	Art. no.	Capacity kg	Lift stroke mm	Lowest height mm	Length mm	Width mm	Lift time sec	kW	Weight kg pack. incl.	Note
TCR 500*	34919	500	630	80	900	600	9	0,75	138	
TCB 600*	33245	600	720	80	1500	900	13	0,75	210	
TCB 600H*	33638	600	970	80	1500	900	19	0,75	210	
▶ TCL 1000*	601234	1000	820	80	1350	800	13	0,75	250	
▶ TCL 1000B*	601241	1000	820	80	1350	1000	13	0,75	275	
TCL 1000GB*	601224	1000	820	80	1350	1270	13	0,75	300	
TCL 2000*	601377	2000	820	100	1350	800	24	0,75	325	
TCL 2000B*	601904	2000	820	100	1350	1000	24	0,75	355	
TCL 2000GB*	601905	2000	820	100	1350	1270	24	0,75	400	

*External external hydraulic power pack

TCB 600H must be secured to the floor by bolts or similar

Access ramp for low profile lifting table

Model	Art. no.	D x W x H	Note
TCR 500	32531	600 x 600 x 80	
TCB-, CCB 1000	35478	600 x 750 x 80	
CCB 1000B, XB	34635	600 x 950 x 80	

Model	Art. no.	D x W x H	Note
TCL 1000	36196	790 x 800 x 80	
TCL 1000B, GB	36228	790 x 1000 x 80	
TCL 2000	36480	950 x 800 x 100	
TCL 2000B, GB	36482	950 x 1000 x 100	

Armlift with tilt from +5° to -40°

Our worldwide-patented Armlift is unique with lift and tilt operation in the same unit. The Armlift has the world's lowest distance between the floor and the platform in its lowest position. Pallets and trolleys can be lifted directly from the floor by parallel arms.



- ▶ ART and ALT have a flat platform
- ▶ ALT U, UE and GB have a U-shaped platform
- ▶ Armlifts with lifting capacity of more than 1,500 kg can be quoted on request.



ALT 1500 GB



ART 1500 fitted with truck handling chassis



ALT 750

Model	Art. no.	Capacity kg	Lift stroke mm	Lowest height mm	Length		Width		Lift time sec	kW	Weight kg pack. incl.	Note
					Outer mm A	Inner mm B	Outer mm C	Inner mm D				
ALT 750*	22035	750	820	235	1300	1245	800	-	18	0,75	300	
ALT 1500	34031	1500	820	235	1300	1245	800	-	16	0,75	355	
ALT 1500U*	34010	1500	820	6	1380	1200	1510	1050	16	0,75	410	
ALT 1500UE*	34085	1500	820	6	1380	1200	1310	850	16	0,75	390	
ALT 1500GB*	34240	1500	820	6	1380	1200	1730	1270	16	0,75	440	
ART 750*	34542	750	550	235	1000	945	1300	-	18	0,75	270	
ART 1500*	22023	1500	550	235	1000	945	1300	-	16	0,75	320	

*External power pack with cover

Load restraint included in models with flat platform (bolted steel)
ALT 750, 1500, ART 750 and 1500 = height 230 mm

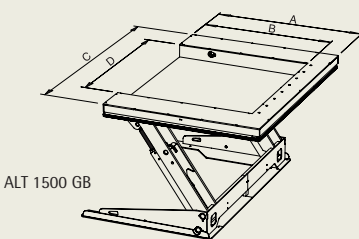

ALT 1500 GB

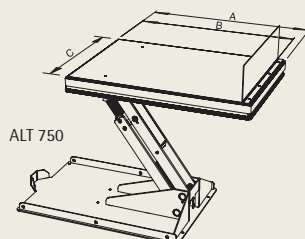

ALT 750

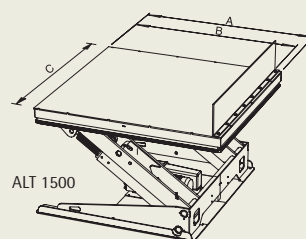

ALT 1500

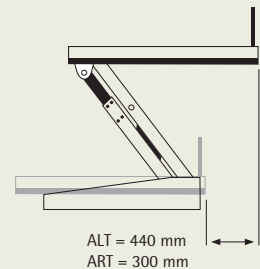

Armlift ARZ for taxi-trains

ARZ is developed together with one of Europe's biggest car manufacturer to provide an ergonomic, safe and profitable material handling without forklift trucks.

Every year, forklift trucks are the cause of a great number of industrial accidents and are also, from a lean perspective, an unprofitable way of transporting material. Taxi-trains, on the other hand, are a more efficient and safe way to transport materials.

Taxi-trains pull several trolleys with materials which can then be unloaded at the respective operator's workplace. The trains are then rolled in on the Armlift in two directions depending on the design of the load restraint. Lift height and tilt angle are easily set manually or automatically and provide the operator with superior access with free leg room.

ARZ is a patented product with cutting edge design, which provides unique opportunities to streamline the flow of materials in a safe and ergonomic way.

SAFE HANDLING OF MATERIALS

- ▶ Extremely compact design means that most standard design taxi-trains work together with the ARZ armlift.
- ▶ Stepless height and tilt adjustment provides great adjustability in presenting material individually for each operator.
- ▶ Modular design provides great flexibility for solutions that meet different needs.

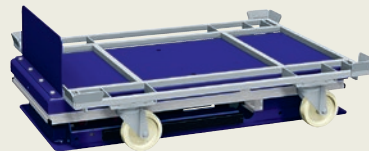
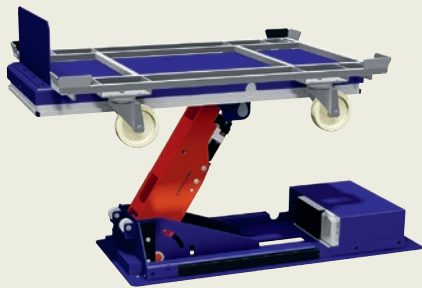

Model	Manual operation *	Automatic operation **	Automatic and manual operation ***
ARZ 750			
ARZ 1200			

*Press and hold control for lifting and tilting

**Single button pressure to initiate motion to the upper or lower position.

***As automatic but with the ability to manually adjust the height during press and hold control

Model	Art. no.	Capacity kg	Lift stroke mm	Lowest height mm	Length mm	Width mm	Lift time sec	Tilt angle	kW	Weight kg pack. incl.	Note
ARZ 750	609300	750	550	220	1300	550	15	+5° -40°	0,37	260	
ARZ 1200	609460	1200	550	220	1020	770	15	+5° -40°	0,75	300	

Height of load restraint in standard design = 230 mm

Tilt tables for table and floor mounting

EdmoLift offers a full tilt table programme with many different tilt combinations.

When mounted on lift tables, the hydraulics for the tilt and lift table are synchronised.

Floor-mounted tilt tables have their own legs and built-in hydraulic power pack.

- ▶ We have a wide range of tilts. Contact EdmoLift for other tilt combinations and prices.

TECHNICAL DATA FOR COMBINATION OPTIONS

- ▶ Single-acting hydraulics 45° tilt angle
- ▶ Double-acting hydraulics 90° tilt angle
- ▶ Torque 6.5 kNm, 13 kNm and 18 kNm
- ▶ Platform lengths 900 mm, 1300 mm, 1700 mm
- ▶ Platform widths 600 mm, 800 mm, 1000 mm
- ▶ Load restraint 230 mm included
- ▶ Tilt direction to short or long side



ESL 130 fitted on a TL 2000

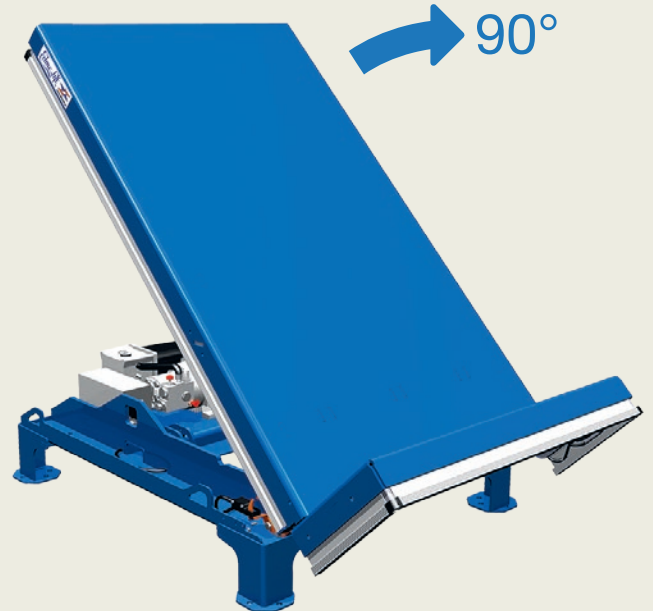

EDLF 65 has double-acting hydraulics and 90° tilting over short side.

WHEN REQUESTING A QUOTE PLEASE PROVIDE THE FOLLOWING INFORMATION

- ▶ Length, width and height of the load
- ▶ Position of centre of gravity
- ▶ Load weight
- ▶ Tilt angle

Model	Art. no.	Length mm	Width mm	Lowest height mm	Tilt angle	Hydraulic	Tilting over	Torque kNm	kW	Weight kg pack. incl.	Execution	Note
EDLF 65	36085	1300	800	320	90°	Double acting	800	6,5	0,75	165	Floor mounting	
ESLF 65	36076	800	1300	320	45°	Single acting	1300	6,5	0,75	165	Floor mounting	

Pallet Lifters

The pallet lift has clear leg and foot space on three sides which gives superior access and makes working simpler and more efficient. A pallet or container can be placed directly onto the pallet lifter with a hand pallet truck or forklift truck.



TSL 1503

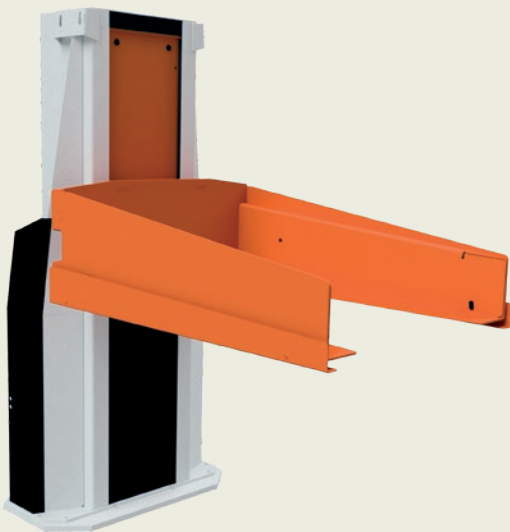

TSLN 1503

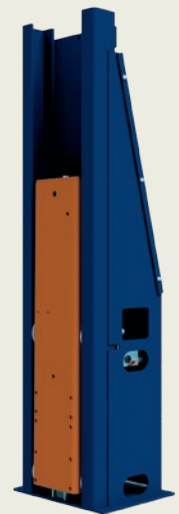

Column TSL with hydraulic power pack for fitting various fixtures, forks or platforms.

Transport trolley for TSL 750, TSLN 750
Art. no.: 32735



Transport trolley for TSL, TSLN

Pallet Lifters

Model	Art. no.	Capacity kg	Lift stroke mm	Lowest height mm	Length mm	Width mm	Lift time sec	kW	Weight kg pack. incl.	Note
TSL 750	33280	750	900	70	1245	850	13	0,75	250	
TSL 1503	613209	1500	880	50	1250	840	26	0,75	670	
TSE 750	33325	750	900	10	1245	1040	13	0,75	340	

Pallet lifter with 40° tilt left and right

Model	Art. no.	Capacity kg	Lift stroke mm	Lowest height mm	Length mm	Width mm	Lift time sec	kW	Weight kg pack. incl.	Note
TSLN 750	35165	750	900	70	1245	850	13	0,75	275	
TSLN 1503	613195	1500	880	50	1250	540	26	0,75	710	

Column with integrated hydraulic power pack

Model	Art. no.	Capacity kg	Lift stroke mm	Fixed to ground with	Bolt and torque for accessory	Lift time sec	kW	Weight kg pack. incl.	Note
Column TSL 750	33285	750	900	8 x M12	4 x M12/81 Nm	13	0,75	160	

Accessories for lift tables and there location

To EdmoLift's lift tables a variety of accessories is available which add extra value to your investment.

On the following pages there are illustrations of the most common accessories that we can equip our products with.

There are some important issues that should be considered in the selection and placement of accessory and the environment of the lift table:

SAFE HANDLING OF MATERIALS

- ▶ Will there be someone travelling on the lift table?
- ▶ Will the lift table be installed in a pit?
- ▶ Will the lift table be run over in closed height?
- ▶ Will the lift table be installed outdoors or indoors?
- ▶ Will the lift table be used very intensively?
- ▶ Will additional security features be required around the lift table?
- ▶ Will the lift table need to be moved?
- ▶ Will the load on the platform need to rotate?



Lift table with roller conveyor



Protective bellows mounted on a lift table

HD-execution for lift tables in intensive operation

Lift tables of standard design are fitted for good and prolonged function in "normal" operation. In intensive driving with heavy loads, fast speed, tough environment, and perhaps more shifts requires that the lift table sometimes is oversized and HD-equipped.

HD-execution should be used when the number of lift cycles exceed 10,000/year or if the number of lift cycles is consistently more than 10/hour.

The execution comes with ball-bearing wheels, machined shafts, grease nipples in all leads and drainage of the cylinders to the tank.



Lift table installed in a pit.

Quoted on request

- ▶ EX-classed
- ▶ ESD-execution
- ▶ Other colours
- ▶ Galvanised
- ▶ Stainless steel execution
- ▶ HD-execution

Location of accessory

When accessories are enquired about, EdmoLift explains that each accessory is located according to the above designations, such as guard rail on L1 and L2 and gate on B1 and B2.



Lift table for goods and carriage of passengers.

Extra equipment is located as shown in drawings below

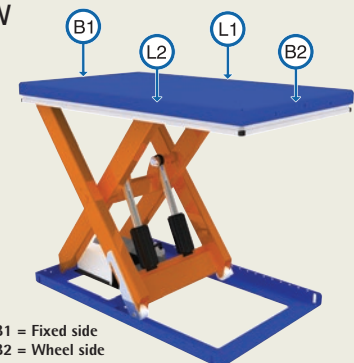
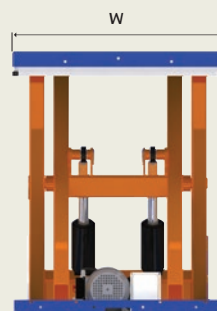
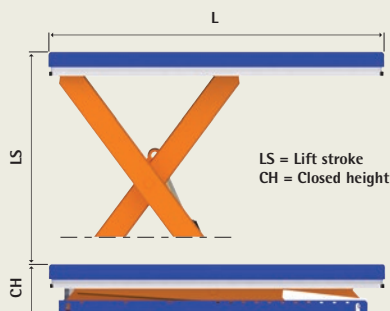

Lift table accessories

- The prices of accessories apply in relation to the purchase of new tables, not for retrofitting, except for articles with article number beginning with R.

Electrical system

521250	Power for automation between upper and lower limit switch	
516790	Electrical equipment for common propulsion	
516792	Electrical equipment with interlock function	
516793	Electrical equipment for passing one limit switch, up	
516794	Electrical equipment for passing one limit switch, down	
521246	Electrical equipment for interlock incl. 2 limit switches, 2 interlocks	
521247	Electrical equipment for automatics incl. 2 limit switches, 2 interlocks	
521270	Electrical equipment for picking automation, up/down	
33019	All connections to block	
82036	CE-plug with 3 meter power cable	
85374	Optional supply cable, price/metre	
526809-UC60	Rotating warning light, visible warning to surroundings	
87051-UC60	Siren, audible warning to surroundings	



Siren
audible warning to surroundings
Art.no: 87051-UC60



Rotating warning light
visual warning to surroundings.
Art.no: 526809-UC60

Control units

516791	Extra control unit 38112 with up/down feature, delivered fitted	
516795	Extra control unit 38114 with four functions up/down/tilt up/tilt down, delivered fitted	
515345-UC60	Control unit, lockable with key	
610132	Foot control unit, comes with lockable emergency stop	
610925	Foot control unit with stand	
514545-1	Control unit stand UC60, adjustable in 3 levels	
Control unit and holder as spare part or retrofit		
R610132	Foot control unit, delivered with lockable control stop	
R38112-02	Control unit, 2 functions	
R38112-01	Control unit, 2 functions with magnetic mount	
R38114-02	Control unit, 4 functions	
R38114-01	Control unit, 4 functions with magnetic mount	
R84880	Extra holder for control unit art.no. 38112 - 38114	
R65315	Control unit 3 wire, up to series 0140523	
R85235	Control unit 5 wire from series 0140524, up to series 2259759 / 5556414	
R84196	Magnetic holder for round control unit with emergency stop 38112, 38114, R65315 and R85235	
Extension cable for UC60 control units with M12 connectors		
86249-3000	Cable M12M-M12F-8 way	extension 3 metres
86249-5000	" " " "	extension 5 metres
86249-10000	" " " "	extension 10 metres
37007	Control unit splitter M12-way. Required when connecting additional control units.	

Control unit UC60

Control unit with lock and emergency stop, 2-4 functions depending on the product model, holder included.
Dual function, art.no: 38112
4 function, art.no: 38114



Extra holder, art.no: R84880

Foot control unit UC60

With two functions. Cord-fitted emergency stop with lock. 3 metre cables are included.
Art.no: 610132



Control unit UC60

for fitting in exposed environments. Dual function with emergency stop with lock.
Art.no: 515345-UC60



Control unit stand UC60

Adjustable into 3 levels
Art.no: 514545-1

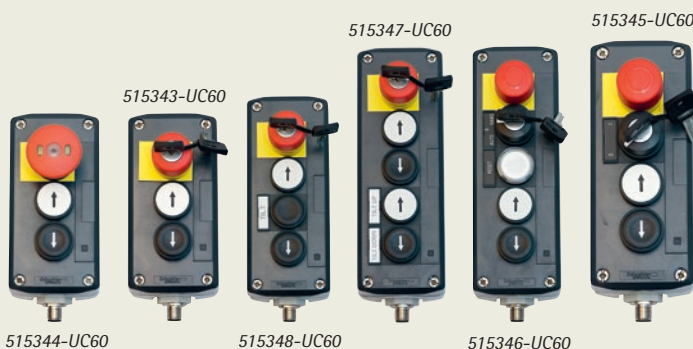

515344-UC60

515348-UC60

515346-UC60

515347-UC60

515345-UC60

Lift table accessories

Hydraulic power packs

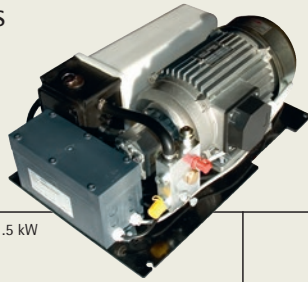

84204	1-phase 230V units up to 1.5 kW	
84205	3-phase 500V units	
32889	Pneumatic unit 1.0kW	
34460	Pneumatic unit 2.0kW	
608619	Battery Power 24V	
	Excluding battery and charger	

Hydraulic fluid

82289	Oil for use in - 20° / litre	
82581	Vegetable oil / litre	

Wheel chassis



The chassis makes it easy to move the lift table and is ergonomically good as the operator has space under the lift table for his feet. The Wheel chassis has two fixed wheels and two swivel, braked wheels.

33575	Wheel chassis	CR 500	height	+240 mm
33940	"	CR 1000	"	+240 mm
524814	"	CB 1200	"	+240 mm
36510	"	CB 1500, B	"	+240 mm
34329	"	CL 1001	"	+240 mm
524813	"	CL 1500	"	+240 mm
36485	"	CL 2000, B	"	+240 mm
518820	"	TR 501, TR 1002	"	+260 mm
518819	"	TL 1000, B, XB	"	+260 mm
33098	"	TL 2000, B	"	+240 mm
524815	"	TL 2000XB	"	+240 mm
36302	"	TL 3000	"	+240 mm
516780	"	TB 2000, B	"	+240 mm
516781	"	TM 1000	"	+240 mm
33136	"	TM 1500, B	"	+260 mm
32693	"	TM 3000	"	+270 mm
33939	"	TA 1000	"	+240 mm
516782	"	TA 2000	"	+270 mm
32583	"	TS 2001, B	"	+270 mm

Truck handling chassis

The chassis makes it easy to move the lift table and is ergonomically good as the operator has space under the table for his feet. The pallet handling chassis provides access to both the short and long sides for outriggers on stackers or outrigger trucks.



36240	Truck chassis	CR 500, CRD 200	height	+140 mm
36241	"	CR 1000	"	+140 mm
524809	"	CB 1200	"	+140 mm
36509	"	CB 1500, B	"	+140 mm
34410	"	CL 1001	"	+140 mm
524808	"	CL 1500	"	+140 mm
36484	"	CL 2000, B	"	+140 mm
518805	"	CLD 1500	"	+140 mm
521441	"	TR 501, TR 1002	"	+140 mm
		TRD 500	"	+140 mm
36238	"	TL, TLD 1000, B, XB	"	+140 mm
36308	"	TL, TLD 2000, B	"	+140 mm
518751	"	TL, TLD 2000XB	"	+140 mm
36301	"	TL 3000	"	+140 mm
513363	"	TB 2000, B, TBD	"	+140 mm
513364	"	TM 1000	"	+140 mm
36234	"	TM, TMD 1500	"	+140 mm
		TM, TMD 3000	"	+140 mm
515803	"	TM 6000	"	+160 mm
36232	"	TA 1000	"	+140 mm
36233	"	TA 2000, TAD	"	+140 mm
36235	"	TA 4000	"	+160 mm
36236	"	TT 3000	"	+160 mm
36289	"	TT 6000	"	+160 mm
36237	"	TS 2001, B	"	+160 mm
36290	"	TS 4000, B	"	+160 mm
516779	"	TP 3000	"	+160 mm
36239	"	TLH 2000	"	+140 mm
36244	"	TMH 3000	"	+140 mm
35396	"	ART 750	"	+140 mm
35398	"	ART 1500	"	+140 mm
35475	"	ALT 750	"	+140 mm
35474	"	ALT 1500	"	+140 mm
35370	"	ALT 1500GB	"	+140 mm

HD-execution

HD-execution should be used when the number of lift cycles exceed 10,000/year or if the number of lift cycles is consistently more than 10/hour.

The execution comes with ball-bearing wheels, machined shafts, grease nipples in all leads and drainage of the cylinders to the tank.

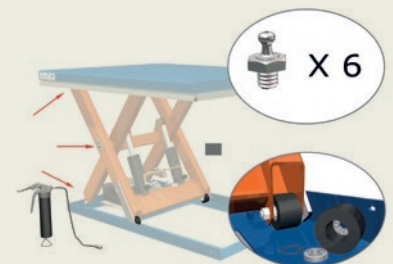

Single Scissors, Vertical Double, Triple and Quattro Scissors			
82103	HD-execution	→ 4000 kg	
82104	"	4000 kg → 10 000 kg	
Horizontal Double Scissors			
82105	HD-execution	→ 4000 kg	
82106	"	4000 kg → 10 000 kg	

Lift table accessories

Scale chassis

The scale chassis is a truck handling chassis with built-in scale that can be fitted to EdmoLift's lift tables with capacities between 500-6,000 kg. The chassis increases the lifting tables total height by 200 mm and is fitted under the lift table. The scales come factory set with a pitch of 0.2 kg and the goods to be weighed are loaded from the lifting tables long or short side using a powered stacker or similar. The scales chassis comes complete with four load cells, scale display with mains and battery supplies.

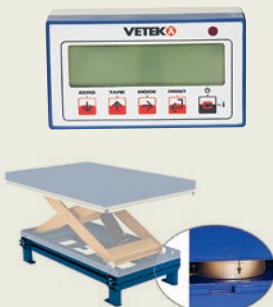

Scales chassis for lift table

Circular turntable

The turntable is fitted on top of the lift table. Locking device is included and can be adapted according to customers' needs. The turntable can also be delivered recessed into a secondary platform, fitted to the main platform.



33258	Top-mounted turntable	1000 kg	Ø650 mm	
33259	Top-mounted turntable	1000 kg	Ø750 mm	
33260	Top-mounted turntable	2000 kg	Ø850 mm	
33262	Top-mounted turntable	2000 kg	Ø1150 mm	

Lifting eye bolts

Lifting eye bolts make it safer and easier to install and transport the lift table. Lifts the base frame through the platform. Some tables require a larger platform. Horizontal double scissor require two sets.

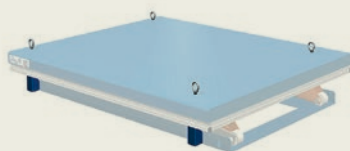

- ▶ Recommended for installation in pits

33960	4 x lifting eye bolts, max load up to → 4000 kg	
33960M20	4 x lifting eye bolts, max load from 4000 kg →	

Rectangular turntable

The turntable is fitted on the platform and includes an inductive sensor to avoid trapping risks. The turntable has safety spacing and is electrically controlled so that the lift cannot be lowered if the turntable is not in the right position.



Rectangular turntable 1000 kg	
Rectangular turntable 2000 kg	

External power pack

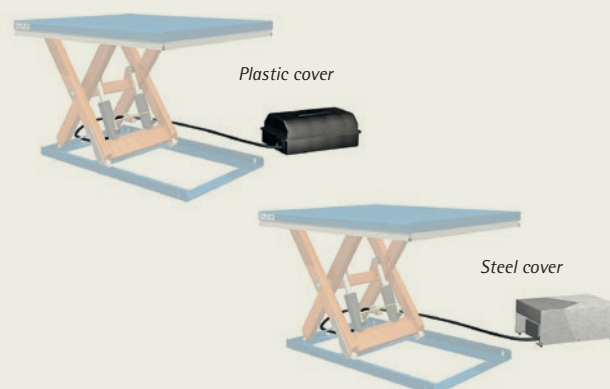

34197	External hydraulic power pack without cover, 3 m hose	
82614	Extra hose external hydraulic pack, price/meter	
External power pack in plastic cover The plastic cover provides good protection for the power pack. For units with sizes up to max H6-4		
33121	Plastic cover for external hydraulic power unit, max. H6-4	
External power pack with steel cover Provides additional protection in exposed environments.		
34696	Steel cover for external power packs. H2, H3, H4, H6-4, H6-7	
34695	" " " " H6-11, H8-11	
34694	" " " " H11-11	
515004	" " " " H11-30, H15-30	
35003	" " " " H15-20	
35948	" " " " H15-50	

Limit switch

The limit switch is adjustable and stops the lift at a pre-set height. Select the upper or lower limit, and whether there should be a function for passing the limit.

- ▶ When ordering, specify whether the switch should be for the upper or lower limit.
- ▶ If heights are notified when ordering, the lift table will be pre-set from the factory.
- ▶ Recommended for installation in pit.

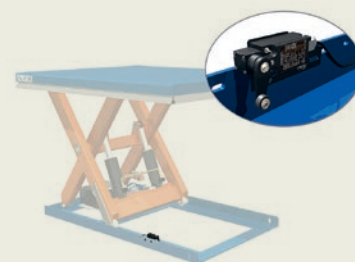

33680	Limit switch CR, CL, CB upper or lower	
515146	Limit switch single, double, triple scissor up to 3,000 kg	
	Limit switch double horizontal scissor up to 6,000 kg	
32003	Limit switch single, double, triple scissor over 3,000 kg	
	Limit switch double horizontal scissors up to 6,000 kg	
34440	Limit switch TSL TSE, upper or lower	
33814	Limit switch TCB TCL TCM, top or bottom	
35970	Limit switch TUB-TUM, top or bottom	

Lift table accessories

Inspection hatch in platform

Suitable for pit-mounted tables with built-in power pack

- ▶ Recommended for installation in pits



33975	Inspection hatch in platform	
-------	------------------------------	--

Mechanical Stop

Used to fix and remove load from the lift table when it is driven over in the bottom position and when adjusting the height to meet roller belts. Adjustable +/-40 mm. Some tables require extension of the platform.

Horizontal double scissors
Requires two sets.

- ▶ Recommended for installation in pits

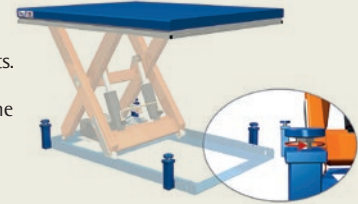

33900	Adjustable +/-40 mm	
-------	---------------------	--

Tipping protection

Caged wheels stabilise the lifting table and minimise the risk for the platform to hinge upward during incorrect loading.

- ▶ Recommended if the platform is extended.

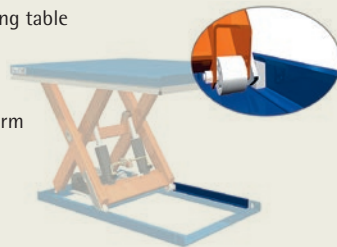

32528	Tipping protection, max load up to → 4000 kg	
33929	Tipping protection, max load from 4000 kg →	

Mechanical locks

Lift tables located in the floor plan can be mechanically locked with hydraulic locking devices coming out from the platform which locks it so that heavy loads could run over the platform.



	Mechanical locks	
--	------------------	--

Loadflap manual / hydraulic

Used for bridging The gap between vehicle, loading dock or other storage area.

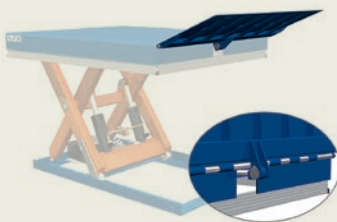

	Manual and hydraulic loadflaps	
--	--------------------------------	--

Rail running chassis

Used to eliminate level differences in a tracked transportation system. The equipment may be motor or manually propelled.

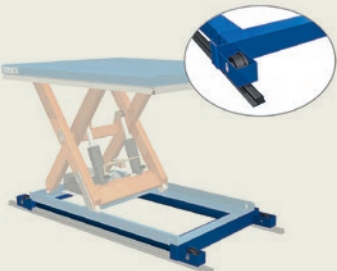

	Rail running chassis	
--	----------------------	--

Roll-off guard

Prevents the load rolling off the platform during loading or unloading. Roll-off guards can be supplied in manual or automatic versions. The automatic roll-off guard rises from the turntable when the lift table starts to elevate.

- ▶ Requires extension of the platform by 150 mm.

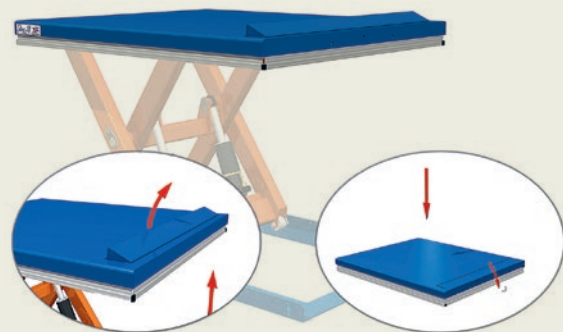

524818	Roll-off guard, automatic	Length 600 mm	
524820	"	" 700 mm	
524821	"	" 800 mm	
524822	"	" 900 mm	
524823	"	" 1000 mm	
524824	"	" 1100 mm	
524826	"	" 1200 mm	
33837	Roll-off guard, manual	Length 600 mm	
33838	"	" 800 mm	
33839	"	" 1100 mm	

Lift table accessories

Reinforced platform

A reinforced platform gives extra support to the lift table when driving over with forklift trucks and it prevents deformation. Mechanical stops in the base frame are also included in these versions. Adjustable +/- 40 mm.



82271	Thicker platform + 2 mm platform maximum thickness 8 mm	
34098	Reinforced platform for 5 tonne wheel pressure, increases the lift tables minimum height by 100 mm	

Roller conveyor

Roller conveyors are widely used in various production systems between locations. When calculating roller conveyors, the length and weight of the products must be stated. Also at which height the lift table must be to load and unload the roller conveyor.

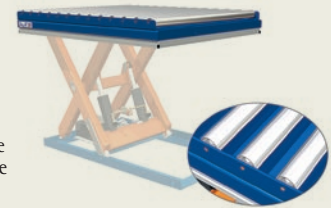

608367	Roller conveyor 1,300x900 mm with two foldable stops 8 rollers, ø76 mm, c-c 150 mm	
611065	Roller conveyor 2000x900 mm with two foldable stops 13 rollers, ø76 mm, c-c 145.8 mm	
Roller conveyor, other sizes		

Guard rail with or without gate

Guard rails and gates are available in different sizes depending on the size of the lift table. The guard rail and gate height is 1,100 mm with a 150 mm high kick board fitted underneath. The gate can be fitted with a manual or electric lock. Recommended for tables that are used as working platforms. Remember to indicate which side the gate should be fitted. See page 54 for more information.

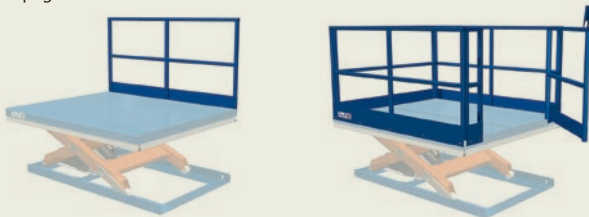

36370	Guard rail 40 x 40 mm with a kick-plate 150 mm	
32467	Guard rail 30 x 30 mm with a kick-plate 150 mm	
36412	Gate with latch - 40 x 40 mm state hinge side max width 1200 mm	
33969	Gate with latch - 30 x 30 mm state hinge side max width 1200 mm	
36412-1	Gate prepared for interlock installation	

Protective skirt and protective wire mesh

Protective skirts increase safety and protect the lift table from dust, dirt and debris in exposed environments. The skirt can be fitted around the entire lift table or just on either side. Requires an extended platform + 75 mm on each side for fitting. Extension is not included in the price.



82280	Protective skirt, orange	
82682	Protective skirt, grey	
32466	Protective wire mesh, galvanised	
33622	Protective bellow PVC TL-table Protective bellow other lift tables	

Non-slip platform

The tear plate platform provide the best anti-slip protection and is recommended for lift tables used outdoors. The chequered aluminium plate is screwed to the platform providing a non-slip, rust-protected surface.

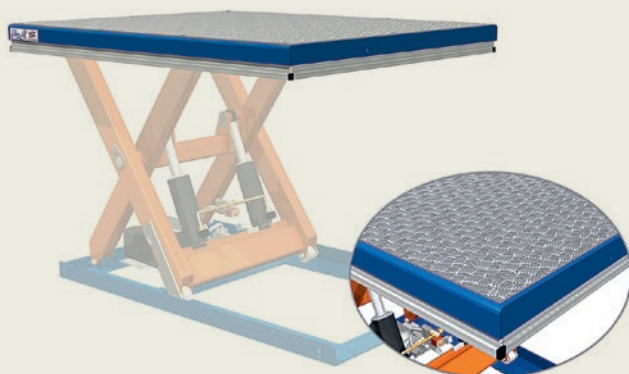

4712	Tear plate platform	
4713	Chequered aluminium	

Pallet Positioner PL 2002



The pallet positioner features integrated turntable and automatic levelling, both up and down. The lift table does not require installation or a power source.

The pallet positioner features pneumatic bellows that can adjust their pressure to the load to be handled, so that the goods are always at the right picking height.

The 1,110 mm turntable holds a EUR-pallet that can be rotated simply and easily. This means that the operator does not need to bend or walk around the pallet to load or unload it.

The lift table handles weights between 150 and 2,000 kg, depending on the air pressure of the bellows.

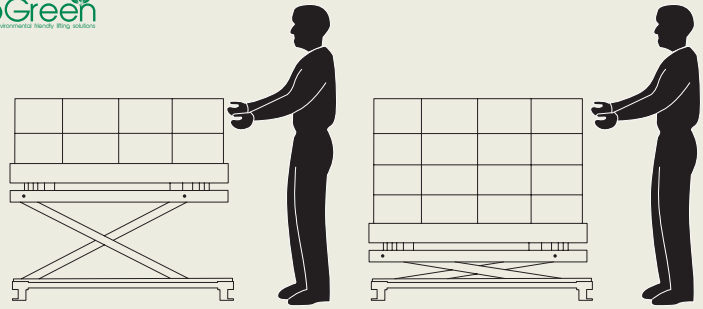

PL 2002

Model	Art. no.	Capacity kg	Lift stroke mm	Lowest height mm	Length mm	Width mm	Total height mm	Rotating turntable Ø mm	Weight kg pack. incl.	Note	Pneumatic with automatic raising/lowering depending on loading.
PL 2002	86944	150 - 2000	464	241	1110	1110	705	1110	220		

Accessories - PL 2002

86946	Truck handling chassis, adjustable height	
-------	---	--

Height = 50 mm, total height = 755 to 825 mm

87132	Protective bellow	
-------	-------------------	--

EdmoLift PALLET BUDDY



PALLET BUDDY for fully automated stacking and destacking of load pallets, is completely electric-powered and easy to install.

Choose a PALLET BUDDY, if you want to efficiently and safely stack and destack one pallet at a time. PALLET BUDDY can also be used for pallet handling in cold storage rooms with temperatures down to - 25 °C (accessory).

You can place it anywhere there is a 230V electric socket. You instantly get efficient and flexible pallet handling - if the pallet flow changes, you can easily move your PALLET BUDDY to a new place.

You can insert and remove pallets with the aid of a pallet trolley, stacker or regular forklift truck. All handling takes place at floor level.

It is also possible to insert or remove an entire stack of pallets directly from PALLET BUDDY - without using a forklift truck.

COLOURS

In the standard version PALLET BUDDY is delivered in RAL 5002 (dark blue), you can choose another colour indicated below free of charge.

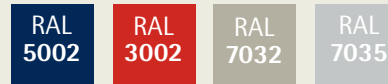

- ▶ Control: Siemens S7-1200
- ▶ Actuator: Linak
- ▶ Power supply: 220-240VAC, 50 Hz



PALLET BUDDY 15 pallets



PALLET BUDDY 25 pallets

Art. no.	Model	Pallet dimensions	Lift capacity	Number of pallets	Note
88100	Pallet magazine Pallet Buddy	1200x800x150	500 kg	15	

Description	Pallet dimensions	Lift capacity	Number of pallets	Note
Adaption for large pallets	1200x1000x150			
25 pallet magazine		700 kg	25	

Accessories for PALLET BUDDY

Truck protection

The truck protection is 10 mm steel and is used as an additional protection for the pallet magazine. The truck protection is supplied in pairs and are bolted to the floor in front of the machine. This solution is recommended in operations where the pallets are often handled with a forklift truck.

88064	Truck protection	
-------	------------------	--



Safety frame gate for 15 pallet magazine

The safety frame is mounted on the pallet magazine's protective superstructure for extra safety. The pallet magazine can only be operated when the safety frame is closed and locked with a safety switch. The safety frame covers the front on the right part of the pallet magazine and reaches from the top of the protective superstructure to the level of the second pallet calculated from floor level.

The safety frame is of the same type that is mounted on the pallet magazine for 25 pallets.

88063	Safety frame	
-------	--------------	--

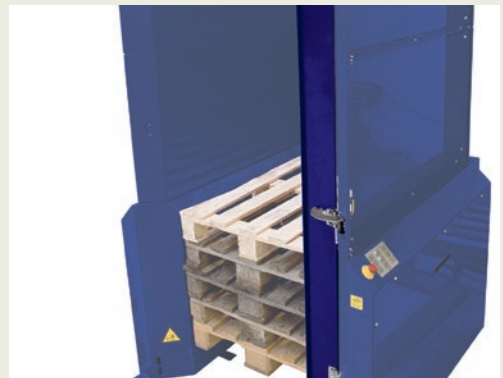

Stop block

A stop block is a perfect accessory when the pallet magazine is to handle pallets where the underlying pallet is transverse relative to the pallet trolley.

When the pallet trolley is pulled out the stop block keeps the pallet in the pallet magazine.

The stop block is installed in front of the sensors in the front edge of the pallet magazine, one on each side.

88068	Stop block	
-------	------------	--



Pallet handling in cold areas

The pallet magazine is adapted with an actuator which is adapted for temperatures down to -25°C.

88067	Pallet handling in cold areas	
-------	-------------------------------	--



Accessories for PALLET BUDDY

Maximum indicator

A sensor that detects when the pallet magazine is loaded at a pre-installed level. If the pallet magazine needs to stay at a certain level for example at 12 pallets, a maximum indicator is fitted on the protection superstructure. When the maximum indicator is activated the whole stack of pallets is put down onto the floor automatically. The pallet stack is then ready for picking up with e.g. a pallet trolley or forklift truck. The operation can also be operated manually from the control panel.

88065	Maximum indicator	
-------	-------------------	--



Light tower with maximum indicator

The light tower includes a sensor that detects when the pallet magazine is loaded at a pre-installed level. If the pallet magazine needs to stay at a certain level for example at 12 pallets, a light tower with a maximum indicator is mounted on the protection superstructure. When the maximum indicator is activated the light begins to light up and the whole pallet stack is put down onto the floor automatically. The pallet stack is then ready for picking up with for example a pallet trolley or forklift truck. The operation can also be operated manually from the control panel.

88066	Light tower with maximum indicator	
-------	------------------------------------	--



Switch disconnecter

With a switch disconnecter it is possible to break the power supply directly at the pallet magazine. It is also possible to lock the switch disconnecter for extra safety for service work for example. The switch disconnecter is positioned under the main supply.

88069	Switch disconnecter	
-------	---------------------	--

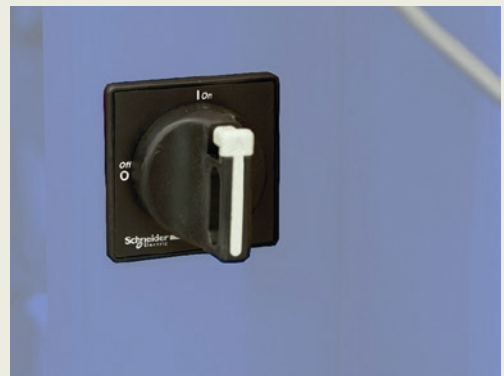

Order accessories when ordering PALLET BUDDY

- ▶ Accessories must be ordered before the pallet magazine is delivered
- ▶ Only the accessory truck protection can be retrofitted.

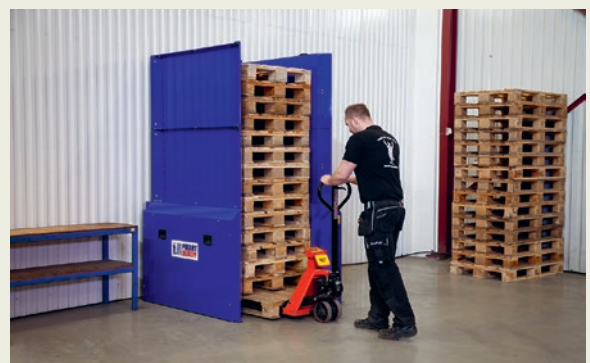

Scissor lift trolleys

Swedish-made trolleys and work tables. Single and double scissors, 200 - 300 - 400 - 500 - 1,000 kg with foot pump or battery operation (charger included) Large easy-rolling wheels with double brakes on the swivelling wheels.

- ▶ The C-models are our affordable option
- ▶ See page 75-81 for stainless alternatives



Scissor lift trolleys

Model	Art. no.	Capacity kg	Maximum height mm	Lowest height mm	Length mm	Width mm	Platform mm	Height adjustment Power	Battery	Weight kg pack. incl.	Note
▶ TZ 303	521443	300	930	330	1150	650	900 x 600	footpump	–	65	
▶ TZ 503	521444	500	930	330	1150	650	900 x 600	footpump	–	75	
▶ TZ 503B	22030	500	930	330	1150	650	900 x 600	0,8 kW	12V 24Ah	90	
▶ EZ 1001B	610490	1000	900	300	1180	800	900 x 800	0,8 kW	12V 28Ah	190	
▶ TZD 203	521445	200	1620	450	1150	650	900 x 600	footpump	–	85	
▶ TZD 203B	22032	200	1620	450	1150	650	900 x 600	0,8 kW	12V 24Ah	100	
▶ TZD 400B	34070	400	1620	450	1230	800	1000 x 800	0,8 kW	12V 24Ah	220	

Scissor lift trolleys C series - affordable lift trolleys. Single and double scissors, 200-500 kg

C-model	Art. no.	Capacity kg	Maximum height mm	Lowest height mm	Length mm	Width mm	Platform mm	Height adjustment	Weight kg pack. incl.	Note
▶ CZ 203	524674	200	930	330	1150	650	900 x 600	footpump	65	
▶ CZ 503	521448	500	930	330	1150	650	900 x 600	footpump	75	
▶ CZD 203	521449	200	1620	450	1150	650	900 x 600	footpump	85	

▶ = normally kept-in-stock products for quick delivery

Work Positioners - Commander Series



The intuitive control unit commander

WORK POSITIONERS DESIGNED FOR OFFICES, PRODUCTION AND RETAIL

The commander series stand out with its outstanding manoeuvrability, intuitive control unit and stylish appearance.

With our ergonomic lift trolleys heavy, strenuous lifting, minimizing the risk of industrial injuries caused by repetitive lifting, moving and handling of heavy objects. The lifting trolleys in the commander series effectively handles weights of up to 90 kg.

MAST AND LIFT FUNCTION

The mast is made up of anodised aluminium with a steel sledge with precision ball bearings, the lifting trolleys are fitted with strong energy-efficient 24VDC motors and powered by a steel reinforced timing belt that does not need any special maintenance.

CONTROL UNIT

to use with their intuitive control unit. The platform can easily be raised and lowered from all sides of the lift.

SAFETY

All moving parts are shielded. The lift has overload protection and safety circuit. The lifters are supplied with a smart charger which automatically stops charging the battery once it is fully charged.

PRODUCT FEATURES

- ▶ The market's fastest lifting speed – 125 mm/sec
- ▶ Outstanding manoeuvrability
- ▶ Low self weight – mast in aluminium, leg and handle in painted steel (the SS models are stainless with mast in aluminium)
- ▶ Quiet operation
- ▶ Wide range of tools and tools such as box handlers, reel handlers, platforms, wider leg frames
- ▶ Operationally reliable – steel reinforced cam belts instead of chain
- ▶ Load centre 400 mm
- ▶ See page 75-81 for stainless alternatives

Load diagram -
load centre 400 mm
The lift's maximum capacity depends on how far the goods weight centre is from the mast.

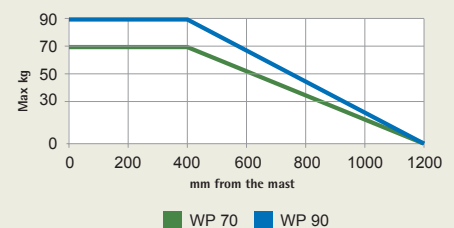

Work Positioners - Commander series

- ▶ When selecting model, remember to select which leg frame the lifting trolley is to be fitted with. See leg options below.



Model	Art. no.	Capacity kg	Max platform height mm	Lowest height mm	Length mm	Width mm	Height mm	Platform LxW mm	Lift time mm/sec	Batteries	Charger	Weight kg	Note
WP 70S**	87419	70	1062	112	721	450	1225	400 x 450	125	24V 7,2Ah	1,8A/24V	27	
WP 70*	87418	70	1357	112	677	455	1517	400 x 450	125	24V 7,2Ah	1,8A/24V	28	
WP 70EM*	87420	70	1757	112	677	455	1917	400 x 450	125	24V 7,2Ah	1,8A/24V	30	
WP 70S SS***	87686	70	1051	101	747	560	1217	495 x 495	125	24V 7,2Ah	1,8A/24V	29	
WP 70 SS***	87687	70	1346	101	747	560	1512	495 x 495	125	24V 7,2Ah	1,8A/24V	30	
WP 70EM SS***	87688	70	1746	101	747	560	1912	495 x 495	125	24V 7,2Ah	1,8A/24V	32	
WP 90S**	87669	90	1062	112	721	450	1225	400 x 450	125	24V 7,2Ah	1,8A/24V	27	
WP 90*	87668	90	1357	112	677	455	1517	400 x 450	125	24V 7,2Ah	1,8A/24V	28	
WP 90EM*	87667	90	1757	112	677	455	1917	400 x 450	125	24V 7,2Ah	1,8A/24V	30	

Charger included Front wheel swivelling Ø75 mm (SS models Ø50 mm) * Rear wheel swivelling Ø125 mm with brake ** Rear wheel Ø300 mm without brake
 *** Semi-stainless, most in aluminium, delivered in ESD-execution (for full ESD protection it is required that the lift trolley is fitted with a tool made of stainless steel).

Wooden platform 87360 is included in the price, plastic platform 87796 is included for WP 70 SS models. When selecting other tool the price is deducted for the included tool. Read more about tools on page 68.

Leg frames for WP 70, 70 SS and 90 Choose among up to four different leg frames

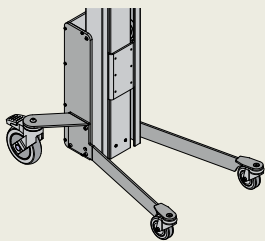

ANGLED
 The unique design gives you free foot space, optimum stability and the absolute best manoeuvrability.

- ▶ Suitable for all models. Standard leg for: WP 70, 70EM, 90 and 90EM

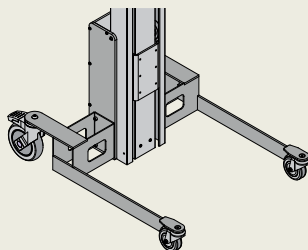

BOX
 Allows forks to go all the way down to the floor, used to lift, e.g. plastic boxes.

- ▶ Suitable for all models. Standard leg for: all WP 70 SS models

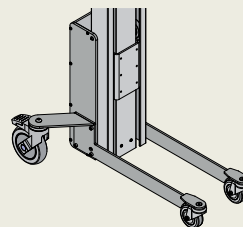

STRAIGHT
 The narrow legs give the lift trolley access to run in under the pallets and chassis. Used where boxes or other goods must be lifted directly from the pallets.

- ▶ Suitable for: WP 70S, WP 70, WP 90S and WP 90

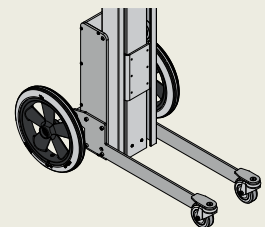

SACK TRUCK
 With large wheels there is no problem pulling the lift trolley over thresholds and edges. Also help to protect fragile loads.

- ▶ Suitable for: WP 70S, WP 90S. Standard leg frame for: WP 70S and WP 90S

Accessories for Work Positioners - Commander Series

Wooden platform

Standard platform for all
WP 70 and WP 90.
Dimensions LxW 400x450 mm

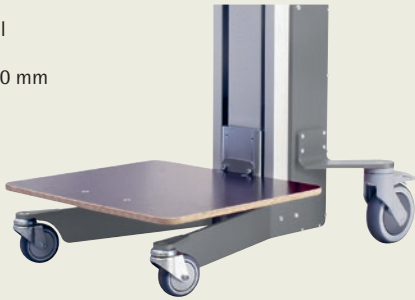

87360

Lifting fork

Galvanised steel
Dimensions LxW 585x375 mm



87416

Plastic platform

Dimensions LxW 495x495 mm

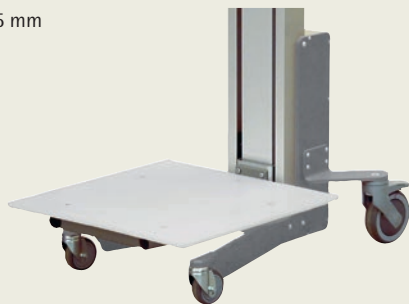

87364

Reel rotator

Rotatable 360°, lift
capacity 20 kg



87373

Plastic platform

With 3 load rollers.
Dimensions LxW 495x495 mm

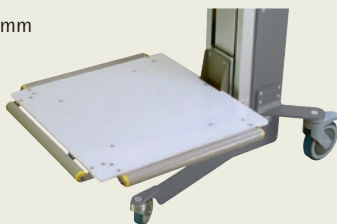

87366

Reel mandrel with front roller and V-cradle,

Max. width of
reel Ø600 mm,
lift capacity WP 70 = 30 kg,
WP 90 = 60 kg



87371

Roll holder

Stainless steel, non-
rotatable, lift capacity
20 kg



87413

Accessories for Work Positioners - Commander Series

Reel mandrel

Length 500 mm,
Ø60 mm



87367

Platform in stainless steel + V-cradle

Platform in stainless steel art.no.: 87372, V-cradle in plastic LxWxH 340x290x80 mm.
Max. width of reel Ø600 mm,
lift capacity WP 70 = 50 kg, WP 90 = 60 kg



87412

Twin mandrel

For reels Ø300-Ø400 mm,
length 500 mm, c-c:250 mm



87369

Reel handler

Rotatable 90°, for reels with core of 3" (76 mm), max. Ø800 mm, maximum length of roll 400 mm
Lift capacity
WP 70 = 30 kg,
WP 90 = 40 kg



87799

Art. no.	Tools/accessories	Fits WP	Note
87360	Wooden platform, standard platform WP 70 and WP 90, marine plywood, LxW 400x450 mm	70, 90	
87361	Wooden platform, marine plywood, LxW 500x500 mm	70, 90	
87362	Wooden platform, marine plywood, LxW 600x600 mm	70, 90	
87364	Plastic platform, LxW 495x495 mm	70, 90	
87365	Plastic platform, LxW 600x600 mm	70, 90	
87796	Plastic platform, standard platform WP 70 SS, support in stainless steel, LxW 495x495 mm	70SS	
87795	Plastic platform, support in stainless steel, LxW 600x600 mm	70SS	
87372	Stainless steel platform, LxW 500x400 mm	70, 90	
87793	Stainless steel platform, support in stainless steel, LxW 500x400 mm	70SS	
87363	Wooden platform with 3 load rollers, marine plywood, LxW 500x500 mm	70, 90	
87366	Plastic platform with 3 load rollers, LxW 495x495 mm	70, 90	
87794	Plastic platform with 3 load rollers, support in stainless steel, LxW 495x495 mm	70SS	
87412	Stainless steel platform + V-cradle, platform art.no.: 87372, V-cradle in plastic LxWxH 340x290x80 mm, max. width of reel Ø600 mm, capacity WP 70=50 kg, WP 90=60 kg	70, 70SS, 90	
87371	Reel mandrel with front roller and V-cradle, max. width of reel Ø600 mm, capacity WP 70=30 kg, WP 90=60 kg	70, 90	
87788	Reel mandrel with front roller and V-cradle, stainless steel, max. width of reel Ø600 mm, capacity WP 70=30 kg	70SS	
87367	Reel mandrel, length 500 mm, Ø60 mm	70, 90	
87368	Reel mandrel, length 800 mm, Ø60 mm	70, 90	
87792	Reel mandrel, stainless steel, length 500 mm, Ø60 mm	70SS	
87791	Reel mandrel, stainless steel, length 800 mm, Ø60 mm	70SS	
87369	Twin mandrel, for reels Ø300-Ø400 mm, length 500 mm, c-c:250 mm	70, 90	
87370	Twin mandrel, for reels Ø400-Ø800 mm, length 500 mm, c-c:350 mm	70, 90	
87790	Twin mandrel, stainless steel, for reels Ø300-Ø400 mm, length 500 mm, c-c:250 mm	70SS	
87789	Twin mandrel, stainless steel, for reels Ø400-Ø800 mm, length 500 mm, c-c:350 mm	70SS	
87373	Reel rotator, rotatable 360°, capacity 20 kg	70, 90	
87413	Reel holder, stainless steel, not rotatable, capacity 20 kg	70, 90	
87799	Reel handler, rotatable 90°, for reels with 3" (76 mm) core, max. Ø800 mm, max length 400 mm, capacity WP 70=30 kg, WP 90=40 kg	70, 90	
87416	Lifting fork, galvanized steel, LxW 585x375 mm	70, 90	
87787	Lifting fork, stainless steel, LxW 585x375 mm	70SS	
87399*	ESD execution, brushes on carriage, conductive rear wheels. ESD requires a tool in stainless steel, not included.	70, 90	

*Cannot be combined with sack truck leg frame

Special dimensions and other customizations can be quoted upon request.

Work Positioners - Industrial Series



POWERFUL WORK POSITIONERS DESIGNED FOR HEAVY LIFTING IN INDUSTRIAL ENVIRONMENTS

The lifting trolleys in the industrial series effectively handle weights of up to 200 kg and is designed with the best ergonomics and flexibility in mind. The entire series can be specially adapted to suit your specific needs.

The Industrial series stands out with its many options, the stable design and outstanding manoeuvrability.

The products are designed for use in confined spaces. By handling heavy loads with a lifting motion where as little muscle power as possible is used, the risk of injuries caused by repetitive lifting, moving and handling of heavy objects is minimised.

MAST AND LIFT FUNCTION

The mast is made up of anodised aluminium with a steel sledge with precision ball bearings, the lifting trolleys are fitted with strong

energy-efficient 24VDC motors and powered by a steel reinforced timing belt that does not need any special maintenance.

CONTROL UNIT

The lift trolleys are fitted with soft start and stop for safe and precise load handling, they are easy to use with a clear button on the control unit.

SAFETY

All parts are shielded. The lift has overload protection and safety circuit. The lifters are supplied with a smart charger which automatically stops charging the battery once it is fully charged.

PRODUCT FEATURES

- ▶ The market's fastest lifting speed – 125 and 270 mm/sec
- ▶ Outstanding manoeuvrability
- ▶ Soft start and stop
- ▶ Quiet operation
- ▶ Wide range of tools and options such as platforms, reel handlers, v-cradles, control units and leg frames.
- ▶ Operationally reliable - steel reinforced cam belts instead of chain
- ▶ Load centre 400 mm
- ▶ See page 75-81 for stainless alternatives



Easy to use control unit

*Load diagram - load centre 400 mm
The lift's maximum capacity depends on how far the goods weight centre is from the mast.*

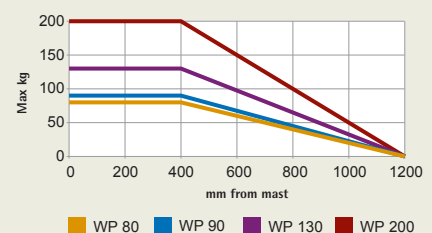

Work Positioners - Industrial Series

When selecting model, remember to select which leg frame the lifting trolleys is to be fitted with.

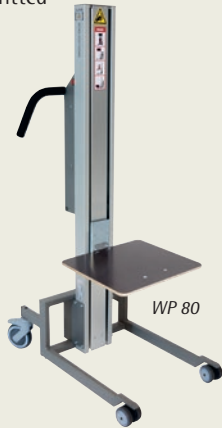

Model	Art. no.	Capacity kg	Max platform height mm	Lowest height mm	Length mm	Width mm	Height mm	Platform LxW mm	Lift time mm/sec	Batteries	Charger	Weight kg	Note
WP 80	87684	80	1314	104	848	534	1520	400 x 450	125	24V 9Ah	2A/24V	30	
WP 80EM	87685	80	1705	104	848	534	1920	400 x 450	125	24V 9Ah	2A/24V	31	
WP 90S Q	87670	90	1302	102	848	534	1520	500 x 500	125/270	24V 9Ah	2A/24V	43	
WP 90 Q	87671	90	1702	102	848	534	1920	500 x 500	125/270	24V 9Ah	2A/24V	45	
WP 90EM Q	87672	90	2102	102	848	534	2320	500 x 500	125/270	24V 9Ah	2A/24V	47	
WP 130S	87673	130	1300	110	848	534	1520	500 x 500	125	24V 9Ah	2A/24V	43	
WP 130	87674	130	1700	110	848	534	1920	500 x 500	125	24V 9Ah	2A/24V	45	
WP 130EM	87675	130	2100	110	848	534	2320	500 x 500	125	24V 9Ah	2A/24V	47	
WP 130EMX*	87737	130	2336	116	848	534	2500	500 x 500	125	24V 9Ah	2A/24V	50	
WP 130EMXX*	87739	100	2927	116	848	534	3046	500 x 500	125	24V 9Ah	2A/24V	53	
WP 200S	87676	200	1284	84	848	534	1567	500 x 400	125	24V 9Ah	3A/24V	55	
WP 200	87677	200	1682	84	848	534	1976	500 x 400	125	24V 9Ah	3A/24V	57	
WP 200EM	87678	200	2084	84	848	534	2376	500 x 400	125	24V 9Ah	3A/24V	59	

Charger included *WP 130EMX and WP 130EMXX are equipped with flex leg frame (included in the price). Select combination on page 70.
 Prices include: wooden platform 87360 for WP 80, wooden platform 87361 for WP 90 Q and WP 130 as well as platform made of stainless steel 87613 for WP 200.
 When selecting another tool the price is deducted for the included tool. Read more about tools on page 74.

Standard leg frame

If no legs or wheels are specified, the lifting trolleys are supplied with the following leg frame. Length 500 mm, inner width 430 mm, outer width 480 mm, rear wheel Ø125 mm swivelling with brake, front wheel Ø75 mm dual swivelling*.

Does not fit: WP 130EMX and EMXX
 *WP 200 models are fitted with front Ø80 mm, fixed.

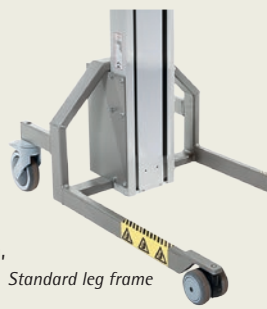

Centred leg frame

Does not fit:
 WP 90EM Q
 WP 130EM, EMX, EMXX
 WP 200, S, EM.

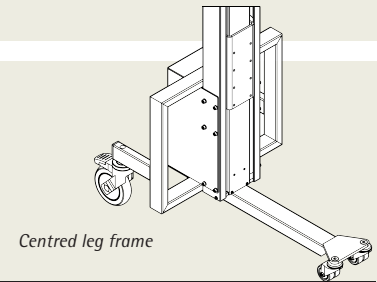

Model	Art. no.	Length mm	Note
Centre leg 1	87786	450	
Centre leg 2	87785	600	

Flexible leg frame

Central brake in 3 positions, swivelling wheel, fixed (permanently straight) wheel and brake. Select length, front wheel and pre-set width. The width can be adjusted afterwards with 5 step positions of + 40 mm.

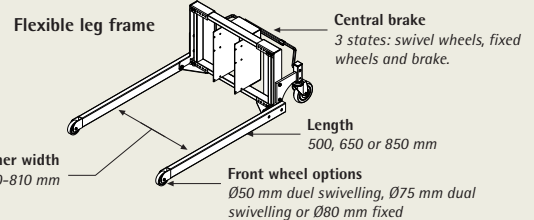
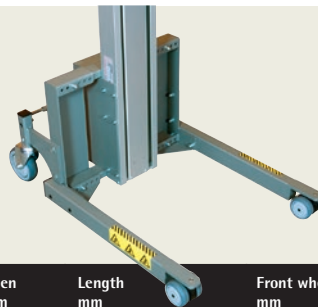

Model	Art. no.	Inside width (width will be less when selecting double swivel wheels) mm	Length mm	Front wheels mm	Note
Flex leg 1	87784	450, 490, 530, 570 or 610	500, 650 or 850	Ø50 double swivel*, Ø75 double swivel** or Ø80 fixed	
Flex leg 2	87783	650, 690, 730, 770 or 810	500, 650 or 850	Ø50 double swivel*, Ø75 double swivel** or Ø80 fixed	

**Does not fit WP 200, S and EM.
 *Max load 130 kg

Width 810 mm, in order to go outside a EUR pallet (1,200 x 800 mm) is only possible with Ø80 mm fixed front wheel.

Accessories for Work Positioners - Industrial Series

Control unit

With buttons in the handle, vertically adjustable



87733

Arrow and stickers

For level adjustment, the arrow is fixed on the sledge and the stickers on the mast, used for quick height indication



87734

Control unit

With spiral cable



87730

Mandrel enlarger

For handling of reels with a core of 6" (152 mm), quick release bracket, fits reel rotator 87618 and 87923

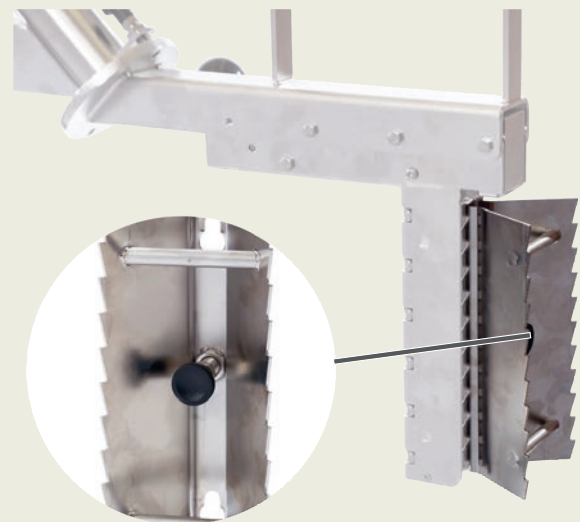

87627

Quick release bracket

Part for the sledge and part for the tool



87798 & 87797

Art. no.	Accessories	Fits WP	Note
87733	Control unit, with buttons in handle, adjustable in height	130, 200	
87730	Control unit, with spiral cable	80, 130, 200	
87922	Exchangeable battery, quick swap, includes wall mounted charger station and two batteries 24V/9Ah. Requires flex leg frame to be equipped (add-on price)	90, 130, 200	
87729	Mounted spiral cable for charger, used instead of the standard external charger cable	80, 90, 130	
87734	Marking arrow with stickers, arrow fitted on the sledge and stickers on the mast, used for quick height indication	80, 90, 130, 200	
87720	ESD execution, brushes on carriage, conductive rear wheels. ESD requires a tool in stainless steel, not included.	80, 90, 130, 200	
87798	Quick release bracket, part for sledge	80, 90, 130, 200	
87797	Quick release bracket, part for tool	80, 90, 130, 200	
87627	Mandrel enlarger, for reel rotator 87618 and 87923, for reels with 6" (152 mm) core, quick mounting and unmounting	80, 90, 130, 200	
87628	Mandrel enlarger, for reel rotator 87618 and 87923, for reels with 10" (254 mm) core, quick mounting and unmounting	80, 90, 130, 200	

Tools for Work Positioners – Industrial Series

Wooden platform

Dimensions LxW 500x500 mm,
standard platform for
WP 90 Q and 130

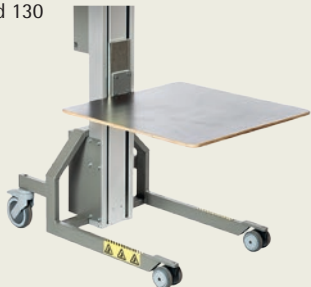

87361

Plastic platform

With 3 load rollers,
dimensions LxW
495x495 mm



87366

Plastic platform

Dimensions LxW 495x495 mm



87364

Platform in stainless steel

Dimensions LxW 500x400 mm,
support in painted steel

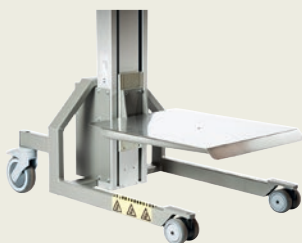

87372

Reel rotator

Rotatable 360°, lift
capacity 20 kg



87373

Reel mandrel

Length 500 mm,
Ø60 mm



87367

Twin mandrel

For reels Ø300-Ø400 mm,
length 500 mm, c-c: 250
mm



87369

Lifting fork

Galvanised steel,
dimensions LxW 585x375 mm

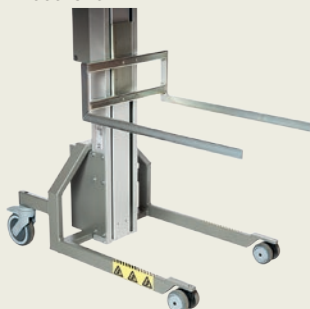

87416

Reel handler

Rotatable 90°, swing ±15°, for reels with
core of 3" (76 mm), max. Ø900 mm, max.
length of reel 500 mm,
lift capacity WP 80 and 90 = 50 kg,
WP 130 = 80 kg, WP 200 = 100 kg



87618



Reel handler

With motorised expansion
and rotation, stainless
steel, rotatable 90°, for
reels with cores of 3" (76
mm), max. Ø900 mm, max.
length of reel 500 mm, lift
capacity 140 kg

87923

Drum turner

With motorised grip and rotation, tips forwards,
stainless steel, max. Ø600 mm, max. length
of goods 900 mm, 4 grippers with 2 rolls per
support, gripper's total height 120 mm, lift
capacity 100 kg

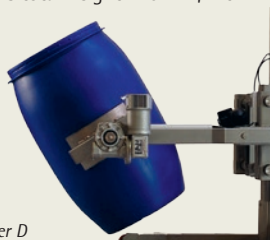

87926 with gripper D

Tools for Work Positioners - Industrial Series

Reel handler

Rotatable 90°, for reels with cores of 3" (76 mm), max. Ø800 mm, max. length of reel 400 mm, lift capacity 40 kg



87799

Platform in stainless steel + V-cradle

Platform in stainless steel art.no.: 87372, V-cradle made of plastic LxWxH 340x290x80 mm, max. width of reel Ø600 mm, lift capacity WP 80 = 60 kg, WP 90 = 60 kg, WP 130 = 90 kg



87412

Reel mandrel with front roller and V-cradle

Max. width of reel Ø600 mm, lift capacity WP 80 = 40 kg, WP 90 and 130 = 60 kg



87371

Drum turner

With motorised grip and rotation, turns sideways, stainless steel, max. Ø610 mm, 4 grippers with 2 rollers per support, gripper's total height 120 mm, lift capacity 100 kg

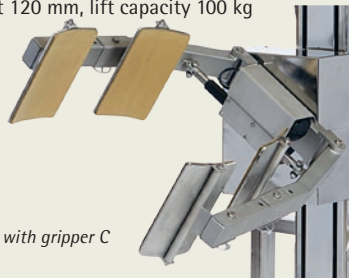

87924 with gripper C

Jib arm with lifting hook

Stainless steel, length 800 mm, swing ± 15°, lift capacity varies depending on load's position and type of leg frame. WP 80 = 60-80 kg, WP 90 = 60-90 kg, WP 130 = 100-130 kg



87724

Drum turner

With motorised grip and rotation, turns sideways, stainless steel, max. Ø600 mm, 4 grippers with 2 rolls per support, gripper's total height 120 mm, lift capacity 150 kg



87925 with gripper C

Fixed V-cradle

For long reels, dimensions V-cradle LxW 400x700 mm, lift capacity WP 80 = 50 kg, WP 90 = 80 kg, WP 130 = 100 kg

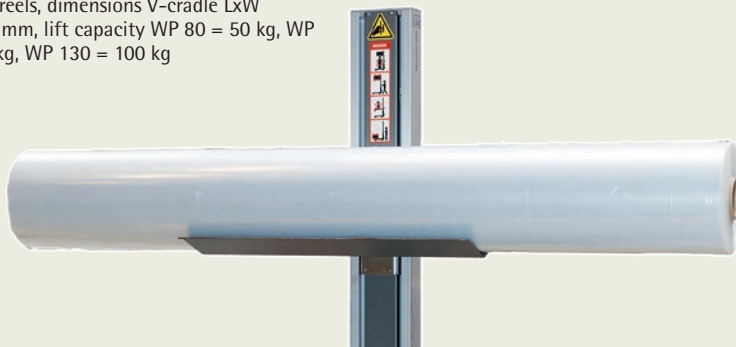

87725



WP 130, fitted with fixed V-cradle



WP 130, fitted with plastic platform with 3 load rollers

87366



WP 80, fitted with jib arm with lifting hook

87723

Tools for Work Positioners – Industrial Series

Art. no.	Tools	Fits WP	Note
87360	Wooden platform, marine plywood, LxW 400x450 mm, standard platform WP 80	80	
87361	Wooden platform, marine plywood, LxW 500x500 mm, standard platform WP 90 Q and 130	80, 90 Q, 130	
87362	Wooden platform, marine plywood, LxW 600x600 mm	80, 90 Q, 130	
87364	Plastic platform, LxW 495x495 mm	80, 90 Q, 130	
87365	Plastic platform, LxW 600x600 mm	80, 90 Q, 130	
87372	Stainless steel platform, support in painted steel, LxW 500x400 mm	80, 90 Q, 130	
87721	Stainless steel platform, support in painted steel, LxW 500x500 mm	80, 90 Q, 130	
87613	Stainless steel platform, support in stainless steel, LxW 500x400 mm, standard platform WP 200	200	
87620	Stainless steel platform, support in stainless steel, LxW 500x500 mm	200	
87363	Wooden platform with 3 load rollers, marine plywood, LxW 500x500 mm	80, 90 Q, 130	
87366	Plastic platform with 3 load rollers, LxW 495x495 mm	80, 90 Q, 130	
87412	Stainless steel platform + V-cradle, platform art.no: 87372, V-cradle in plastic LxWxH 340x290x80 mm, max. width of reel Ø600 mm, capacity WP 80=60 kg, WP 90=60 kg, WP 130=90 kg	80, 90 Q, 130	
87371	Reel mandrel with front roller and V-cradle, max. width of reel Ø600 mm, capacity WP 80=40 kg, WP 90 and 130=60 kg	80, 90 Q, 130	
87722	Reel mandrel with front roller and V-cradle, V-cradle in stainless steel, max. width of reel Ø600 mm, capacity WP 80=40 kg, WP 90 and 130=60 kg	80, 90 Q, 130	
87725	Fixed V-cradle, for long reels, LxW 400x700 mm, capacity WP 80=50 kg, WP 90=80 kg, WP 130=100 kg	80, 90 Q, 130	
87367	Reel mandrel, length 500 mm, Ø60 mm	80, 90 Q, 130	
87368	Reel mandrel, length 800 mm, Ø60 mm	80, 90 Q, 130	
87616	Reel mandrel, stainless steel, length 500 mm, Ø60 mm	200	
87621	Reel mandrel, stainless steel, length 800 mm, Ø60 mm	200	
87369	Twin mandrel, for reels Ø300-Ø400 mm, length 500 mm, c-c: 250 mm	80, 90 Q, 130	
87370	Twin mandrel, for reels Ø400-Ø800 mm, length 500 mm, c-c: 350 mm	80, 90 Q, 130	
87617	Twin mandrel, stainless steel, for reels Ø350-Ø450 mm, length 500 mm, c-c: 300 mm	200	
87622	Twin mandrel, stainless steel, for reels Ø450-Ø800 mm, length 500 mm, c-c: 400 mm	200	
87723	Jib arm with lifting hook, stainless steel, length 600 mm, swing ±15°, max load depends of position of load & type of legs WP 80=60-80 kg, WP 90=60-90 kg, WP 130=100-130 kg	80, 90 Q, 130	
87724	Jib arm with lifting hook, stainless steel, length 800 mm, swing ±15°, max load depends of position of load & type of legs WP 80=60-80 kg, WP 90=60-90 kg, WP 130=100-130 kg	80, 90 Q, 130	
87619	Jib arm with lifting hook, stainless steel, length 600 mm, no swing option, max load 150-200 kg depends of position of load and type of legs	200	
87625	Jib arm with lifting hook, stainless steel, length 800 mm, no swing option, max load 150-200 kg depends of position of load and type of legs	200	
87373	Reel rotator, rotatable 360°, capacity 20 kg	80	
87413	Reel holder, stainless steel, not rotatable, capacity 20 kg	80	
87799	Reel handler, rotatable 90o, for reels with 3" (76 mm) core, max Ø800 mm, max length of reel 400 mm, capacity 40 kg	80, 90 Q, 130	
87618	Reel handler, stainless steel, rotatable 90o, swing ±15°, for reels with 3" (76 mm) core, max Ø900 mm, max length of reel 500 mm, capacity WP 80 och 90=50 kg, WP 130=80 kg, WP 200=100 kg	80, 90 Q, 130, 200	
87923*	Reel handler with motorised expansion and rotation, stainless steel, rotatable 90°, for reels with 3" (76 mm) core max Ø900 mm, max length 500 mm, capacity 140 kg	200	
87924*	Drum turner with motorised grip and turning, turning sideways, stainless steel, max Ø610 mm, 4 rolling grippers with total height 120 mm included, capacity 100 kg	200	
87925*	Drum turner with motorised grip and turning, turning sideways, stainless steel, max Ø600 mm, 4 rolling grippers with total height 120 mm included, capacity 150 kg	200	
87926*	Drum turner with motorised grip and turning, tipping forward, stainless steel, max Ø600 mm, max length 900 mm, 4 rolling grippers with total height 120 mm included, capacity 100 kg	200	
87931	Control box for motorised lifting tools, can only be used in combination with motorised lifting tool	200	
87416	Lifting fork, galvanized steel, LxW 585x375 mm	80, 90 Q, 130	
87614	Lifting fork, stainless steel, LxW 570x380 mm	200	

* Control box 87931 and flexible leg frame (page 70) is required to use motorised tools (additional price)

Special dimensions and other customizations can be quoted upon request.

Grippers for motorised drum turners

All motorised drum turners comes equipped with 4 rolling grippers with a total height 120 mm.

Optional grippers can be selected for an add-on price.

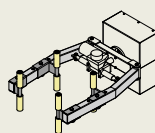

Drum turner 87924 equipped with Gripper A

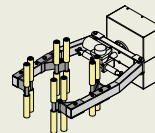

Drum turner 87924 equipped with Gripper B

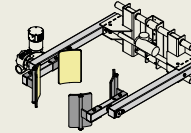

Drum turner 87926 equipped with Gripper C

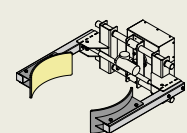

Drum turner 87925 equipped with Gripper D

Model	Art. no.	Gripper	Note
Gripper A	87927	4 rolling grippers, total height 260 mm.	
Gripper B	87928	4 set of double rolling grippers, total height 360 mm, for gripping soft items and items in different shapes (round/square).	
Gripper C	87929	4 curved plates with rubber, height 260 mm, flexible in horizontal direction for gripping items with different diameters.	
Gripper D	87930	2 fixed and curved plates with rubber, for gripping heavy or soft drums/items in the same diameter.	

Lifting solutions in stainless steel

– FOR AGGRESSIVE ENVIRONMENT AND HIGH REQUIREMENTS OF CLEANING

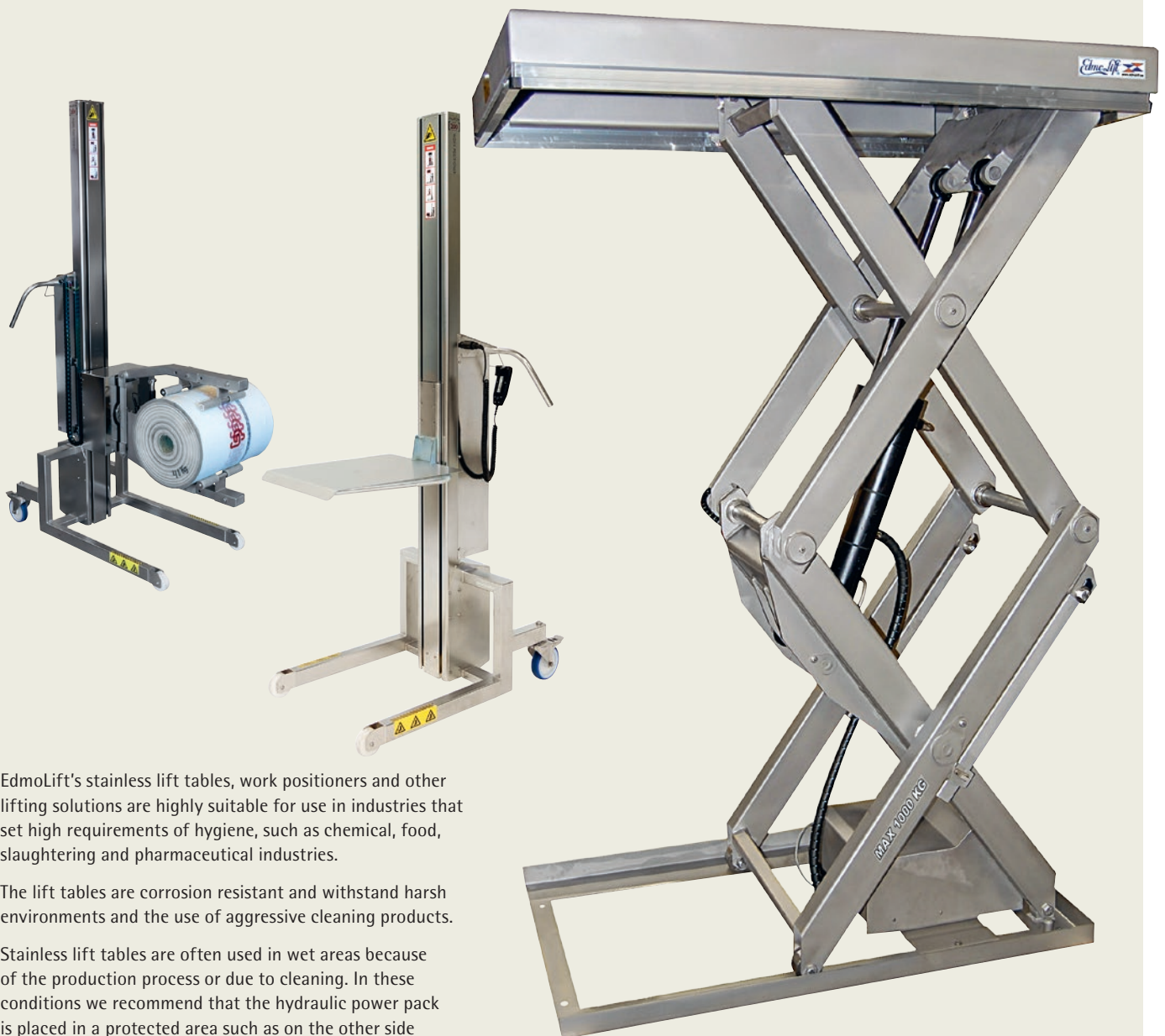

EdmoLift's stainless lift tables, work positioners and other lifting solutions are highly suitable for use in industries that set high requirements of hygiene, such as chemical, food, slaughtering and pharmaceutical industries.

The lift tables are corrosion resistant and withstand harsh environments and the use of aggressive cleaning products.

Stainless lift tables are often used in wet areas because of the production process or due to cleaning. In these conditions we recommend that the hydraulic power pack is placed in a protected area such as on the other side of a nearby wall. If these recommendations unnecessary downtime will be avoided in the future.



Stainless steel single scissors

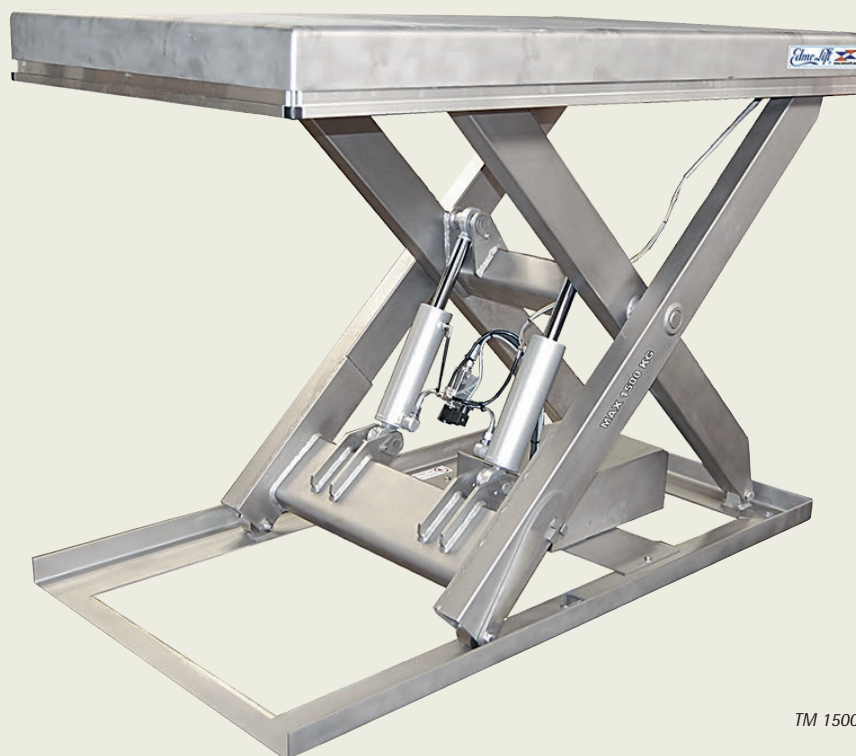

TM 1500SS

Our stainless lift table is made of material with high quality. The platform, base frame and scissors are stainless, in accordance with standard AISI 304/EN 1.4301 (SS 2333). A steel with very high corrosion resistance.

Axles, wheels and bolts are stainless, in accordance with standard AISI 303 / EN 1.4305. A steel with high corrosion resistance.

Nipples and pipes are of electro-zinc plated standard quality.

Wheels of stainless steel / polyurethane.

As standard cylinder type 2 are included with extra surface treatment, piston rod and cylinder tube are in stainless steel. The cylinder tube is sandblasted, primed and painted with two coats of polyurethane 2-component paint. Nipples are electro-zinc plated.

QUOTES PROVIDED FOR SELECTABLE CYLINDERS

Cylinder type 1: regular surface treatment with polyurethane 2-component paint. Nipples are electro-zinc plated.

Cylinder type 3 in stainless steel: cylinder of AISI 316/EN 1.4401 (SS 2347), piston rod of AISI 329/EN 1.4460, cylinder tube in AISI 420/EN 1.4031, nipples of AISI 316/EN 1.4401 (SS 2347).

TECHNICAL SPECIFICATIONS

Stainless lift tables are often used in wet areas because of the production process or due to cleaning. In these conditions we recommend that the hydraulic power pack is placed in a protected area e.g. on the other side of a nearby wall. If these recommendations unnecessary downtime will be avoided in the future.

AS STANDARD ALL STAINLESS STEEL LIFT TABLES ARE EQUIPPED WITH:

- ▶ Pressure compensating lowering valve
- ▶ Safety trip bar on all sides
- ▶ Maintenance safety bars for service
- ▶ Power supply: 3 x 415 V/50Hz + earth + 0
- ▶ Control voltage 24 V DC
- ▶ Electric box: IP 65
- ▶ Switches: IP 65
- ▶ Motor: IP 54
- ▶ Filter system: Filter on oil tank and on oil return side
- ▶ Noise level: 50-52 dB
- ▶ The products are CE marked and conform to the basic requirements of the lifting table standard EN 1570-1

Model	Art. no.	Capacity kg	Lift stroke mm	Lowest height mm	Length mm	Width mm	Lift time sec	kW	Weight kg pack. incl.	Note
TR 500SS	612253	500	550	160	900	650	11	0,37	115	
TL 1000SS	612254	1000	830	180	1300	650	18	0,75	160	
TL 2000SS	612255	2000	820	230	1300	800	27	0,75	240	
TM 1500SS	612256	1500	1100	230	1700	900	27	0,75	315	

Stainless steel vertical double scissors

A lift table with several scissors units mounted vertically makes it possible to achieve a higher lift movement than is possible with a single scissor.

TLD 1000SS



Model	Art. no.	Capacity kg	Lift stroke mm	Lowest height mm	Length mm	Width mm	Lift time sec	kW	Weight kg pack. incl.	Note
TRD 500SS	612257	500	1100	270	900	650	18	0,37	140	
TLD 1000SS	612258	1000	1600	375	1300	800	30	0,75	310	

Low profile lift tables in stainless steel

EdmoLift's stainless lift table TUB 1000 has a very low profile, which makes pit mounting superfluous. With a regular pallet trolley, the pallet can easily be loaded directly on the U-shaped platform. The lift tables can easily be moved for cleaning or for reorganising in the production. Our series of low profile lift tables is specially adapted for load pallets. The TCB tables have a solid platform with a small access ramp.



TUB 1000SS

Model	Art. no.	Capacity kg	Lift stroke mm	Lowest height mm	Length mm	Width mm	Lift time sec	kW	Weight kg pack. incl.	Note
TCB 1000SS*	612259	1000	715	85	1500	800	12	0,75	260	
TUB 1000SS*	612260	1000	715	85	1450	1085	12	0,75	235	

*External hydraulic power pack in cover

Stainless steel scissor lift trolley

Stable lifting trolleys with large, freely running wheels and double brakes on the rear pivoting wheels.

Model	Art. no.	Capacity kg	Maximum height mm	Lowest height mm	Length mm	Width mm	Platform mm	Height adjustment Power	Battery	Weight kg pack. incl.	Note
TZ 303SS	521443RF	300	930	330	1150	650	900 x 600	Footpump	—	65	

Read more about lift trolleys on page 64.

Stainless Steel Work Positioners



STAINLESS STEEL WORK POSITIONERS DESIGNED FOR FOOD AND PHARMA INDUSTRY

The lifting trolleys in the stainless steel series effectively handle weights of up to 300 kg and is designed with the best ergonomics and flexibility in mind. The entire series can be specially adapted to suit your specific needs.

The models WP 90 SS and 200 SS are designed in AISI 304 stainless steel and are IP66 classified, which makes them completely immersible. The WP 70 SS models are semi-stainless with mast in aluminium, leg and handle in stainless steel. These models cannot be flushed.

The products are designed for use in confined spaces. By handling heavy loads with a lifting motion where as little muscle power as possible is used, the risk of injuries caused by repetitive lifting, moving and handling of heavy objects is minimised.

The lifting trolleys in the stainless steel series distinguish themselves with its versatile adaption options, robust design and outstanding manoeuvrability.

CONTROL UNIT

WP 90 SS, 200 SS and 300 SS models are equipped with gentle start and soft as well as control unit with two speeds. WP 70 SS has the same control unit as the lifts in the commando series and provides easy access from all sides of the lift.

MAST AND LIFT FUNCTION

The mast has a steel sledge with precision ball bearings, the lifting trolleys are fitted with strong energy-efficient 24VDC motors and powered by a steel reinforced timing belt that does not need any special maintenance.

SAFETY

All parts are shielded. The lift has overload protection and safety circuit. The lifters are supplied with a smart charger which automatically stops charging the battery once it is fully charged.

PRODUCT FEATURES

- ▶ Electro polished stainless steel and semi-stainless models
- ▶ The market's fastest lifting speed – 125 and 270 mm/second
- ▶ Outstanding manoeuvrability
- ▶ Soft start and stop
- ▶ Quiet operation
- ▶ Wide range of tools and options such as platforms, reel handlers, v-cradles, controll units and leg frames.
- ▶ Operationally reliable – steel reinforced cam belts instead of chain.
- ▶ Load centre 400 mm
- ▶ Two lifting speeds, WP 90 SS, 200 SS and 300 SS

*Load diagram - load centre 400 mm
The lift's maximum capacity depends on how far the goods weight centre is from the mast.*

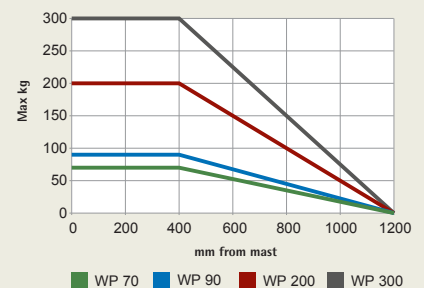

Control unit for WP 70 SS models



Control unit for WP 90 SS Q, 200 SS models

Stainless steel work positioners

► When selecting model, remember to select which leg frame the lifting trolley is to be fitted with.



WP 70 SS



WP 90 SS Q



WP 200 SS

Model	Art. no.	Capacity kg	Max platform height mm	Lowest height mm	Length mm	Width mm	Height mm	platform LxW mm	Lift time mm/sec	Batteries	Charger	Weight kg	Note
WP 70S SS*	87686	70	1051	101	747	560	1217	500 x 400	125	24V 7,2Ah	1,8A/24V	29	
WP 70 SS*	87687	70	1346	101	747	560	1512	500 x 400	125	24V 7,2Ah	1,8A/24V	30	
WP 70EM SS*	87688	70	1746	101	747	560	1912	500 x 400	125	24V 7,2Ah	1,8A/24V	32	
WP 90S SS Q	87761	90	1015	128	746	550	1221	500 x 400	125/270	24V 7,2Ah	1,8A/24V	41	
WP 90 SS Q	87689	90	1304	128	746	550	1516	500 x 400	125/270	24V 7,2Ah	1,8A/24V	44	
WP 90EM SS Q	87690	90	1710	128	746	550	1918	500 x 400	125/270	24V 7,2Ah	1,8A/24V	47	
WP 200S SS	87679	200	1280	80	899	550	1610	500 x 400	125	24V 18Ah	1,8A/24V	67	
WP 200 SS	87680	200	1650	80	899	550	1980	500 x 400	125	24V 18Ah	1,8A/24V	71	
WP 200EM SS	87681	200	2080	80	899	550	2410	500 x 400	125	24V 18Ah	1,8A/24V	76	
WP 300 SS	87682	300	1415	126	1120	580	1970	600 x 600	125	24V 18Ah	3A/24V	105	
WP 300EM SS	87683	300	1765	126	1120	580	2320	600 x 600	125	24V 18Ah	3A/24V	115	

Charger included *Semi-stainless, mast in aluminium, delivered in ESD-execution (for full ESD-protection it is required that the lift trolley is fitted with a tool in stainless steel)

The prices include: plastic platform 87796 for WP 70 SS and WP 90 SS, platform in stainless steel 87613 for WP 200 SS and platform in stainless steel 87892 for WP 300 SS. When selecting another tool the price is deducted for the included tool. Read more about tools on page 81.



WP 70 SS, fitted with platform in stainless steel + V-cradle (87412)



WP 90 SS, fitted with plastic platform (87795)



WP 200 SS, fitted with motorised drum turner (87924)

Leg frame for WP 70 SS & WP 90 SS

Leg frame are included in the price.

WP 70 SS: front wheel Ø50 mm swivelling.

WP 90 SS: choose between front wheel Ø50 mm swivelling wheel or Ø75 mm dual swivel wheel.

ANGLED

The unique design gives you free foot space, optimum stability and the absolute best manoeuvrability.

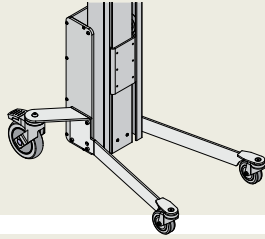

BOX

Allows the forks to go all the way down to the floor. Used for example to lift plastic boxes.

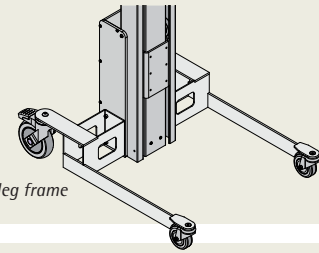

Standard leg frame

Leg frame for WP 200 SS

Leg frames 1-5 are included in the price, additional price for leg frames 6 and 7.

Model	Art. no.	Material	Length mm	Outer width mm	Inner width mm	Note
200 SS leg 1	87629	Aisi 304	500	550	470	Front wheels Ø80 mm fixed - Fits inside a EURO pallet (standard leg)
200 SS leg 2	87630	Aisi 304	650	550	470	Front wheels Ø80 mm fixed - Fits inside a EURO pallet (standard leg motorised tools)
200 SS leg 3	87631	Aisi 304	850	550	470	Front wheels Ø80 mm fixed - Fits inside a EURO pallet
200 SS leg 4	87632	Aisi 304	500	567	453	Front wheels Ø50 mm double swivel - Fits inside a EURO pallet (max capacity 130 kg)
200 SS leg 5	87633	Aisi 304	650	567	453	Front wheels Ø50 mm double swivel - Fits inside a EURO pallet (max capacity 130 kg)
200 SS leg 6	87634	Aisi 304	800	975	890	Front wheels Ø80 mm fixed - Fits outside a EURO pallet

Length is the distance from mast to end of leg.

Rear wheels Ø125 mm swivel with brake.

Customized leg frame for WP 200 SS

Design and drawing included in the price.

Model	Art. no.	Material	Max length mm	Max width outer mm	Inner width mm	Note
200 SS leg 7	87771	Aisi 304	1000	1000	Outer width - 80	Front wheels Ø80 mm fixed or Ø50 mm double swivel

Length is the distance from mast to end of leg.

Rear wheels Ø125 mm swivel with brake.

Leg frames for WP 300 SS

Leg frame 1 and 2 are included in the price, add-on price for leg frame 3-5.

Model	Art. no.	Material	Length mm	Outer width mm	Inner width mm	Note
300 SS leg 1	87662	Aisi 304	600	570	450	Fits inside a EURO pallet (standard leg)
300 SS leg 2	87663	Aisi 304	800	570	450	Fits inside a EURO pallet
300 SS leg 3	87664	Aisi 304	600	960	840	Fits outside a EURO pallet
300 SS leg 4	87665	Aisi 304	800	960	840	Fits outside a EURO pallet

Length is the distance from mast to end of leg.

Front wheels Ø80 mm fixed, rear wheels Ø150 mm swivel with central brake.

Customized leg frame for WP 300 SS

Design drawings are included in the price.

Model	Art. no.	Material	Max length mm	Max width outer mm	inner width mm	Note
300 SS leg 5	87666	Aisi 304	1200	1200	Outer width - 120	

Length is the distance from mast to end of leg.

Front wheels Ø80 mm fixed, rear wheels Ø150 mm swivel with central brake.

Art. no.	Accessories	Fits WP (SS)	Note
87759	Exchangeable battery, quick swap, includes wall mounted charger station and two batteries 24V/18Ah	300	
87772*	IP65 adaption	300	
87720	ESD execution, brushes on carriage, conductive rear wheels. ESD requires a tool in stainless steel, not included.	90, 200, 300	
87627	Mandrel enlarger, for reel rotator 87618 and 87923, for reels with 6" (152 mm) core, quick mounting and unmounting	90, 200, 300	
87628	Mandrel enlarger, for reel rotator 87618 and 87923, for reels with 10" (254 mm) core, quick mounting and unmounting	90, 200, 300	

* Can not be combined with exchangeable battery 87759

Tools - Stainless Steel Work Positioners

Art. no.	Tools	Fits WP (SS)	Note
87796	Plastic platform, support in stainless steel, LxW 495x495 mm, standard platform for WP 70 SS and 90 SS	70, 90	
87795	Plastic platform, support in stainless steel, LxW 600x600 mm	70, 90	
87793	Stainless steel platform, support in stainless steel, LxW 500x400 mm	70, 90	
87613	Stainless steel platform, support in stainless steel, LxW 500x400 mm, standard platform for WP 200 SS	200	
87620	Stainless steel platform, support in stainless steel, LxW 500x500 mm	200	
87892	Stainless steel platform, customized, max. LxW 600x600 mm, standard platform for WP 300 SS	300	
87794	Plastic platform with 3 load rollers, support in stainless steel, LxW 495x495 mm	70, 90	
87412	Stainless steel platform + V-cradle, platform art.no: 87372, V-cradle in plastic LxWxH 340x290x80 mm, max. width of reel Ø600 mm, capacity WP 70=50 kg, WP 90=60 kg	70	
87788	Reel mandrel with front roller and V-cradle, stainless steel, max. width of reel Ø600 mm, capacity WP 70 SS=30 kg, WP 90 SS=60 kg	70, 90	
87792	Reel mandrel, stainless steel, length 500 mm, Ø60 mm	70, 90	
87791	Reel mandrel, stainless steel, length 800 mm, Ø60 mm	70, 90	
87616	Reel mandrel, stainless steel, length 500 mm, Ø60 mm	200	
87621	Reel mandrel, stainless steel, length 800 mm, Ø60 mm	200	
87898	Reel mandrel, stainless steel, customized, max. length 800 mm, Ø60 mm	300	
87790	Twin mandrel, stainless steel, for reels Ø300-Ø400 mm, length 500 mm, c-c: 250 mm	70, 90	
87789	Twin mandrel, stainless steel, for reels Ø400-Ø800 mm, length 500 mm, c-c: 350 mm	70, 90	
87617	Twin mandrel, stainless steel, for reels Ø350-Ø450 mm, length 500 mm, c-c: 300 mm	200	
87622	Twin mandrel, stainless steel, for reels Ø450-Ø800 mm, length 500 mm, c-c: 400 mm	200	
87900	Twin mandrel, stainless steel, customized, max LxW 800x600 mm	300	
87619	Jib arm with lifting hook, stainless steel, length 600 mm, no swing option, max load 150-200 kg depends of position of load & type of legs	200	
87625	Jib arm with lifting hook, stainless steel, length 800 mm, no swing option, max load 150-200 kg depends of position of load and type of legs	200	
87935	Jib arm with lifting hook, stainless steel, length 600 mm, no swing option, max load 225-300 kg depends of position of load and type of legs	300	
87618	Reel handler, manual, stainless steel, rotatable 90°, swing ±150, for reels with 3" (76 mm) core, max Ø900 mm, max length of reel 500 mm, capacity WP 90 SS=50 kg, WP 200 SS=100 kg	90, 200	
87923*	Reel handler with motorised expansion and rotation, stainless steel, rotatable 90°, for reels with 3" (76 mm) core max Ø900 mm, max length 500 mm, capacity 140 kg	200	
87943*	Reel handler with motorised expansion and rotation, stainless steel, rotatable 90°, for reels with 3" (76 mm) core max Ø900 mm, max length 500 mm, capacity 200 kg	300	
87924*	Drum turner with motorised grip and turning, turning sideways, stainless steel, max Ø610 mm, 4 rolling grippers with total height 120 mm included, capacity 100 kg	200	
87925*	Drum turner with motorised grip and turning, turning sideways, stainless steel, max Ø600 mm, 4 rolling grippers with total height 120 mm included, capacity 150 kg	200	
87926*	Drum turner with motorised grip and turning, tipping forward, stainless steel, max Ø600 mm, max length 900 mm, 4 rolling grippers with total height 120 mm included, capacity 100 kg	200	
87944*	Drum turner with motorised grip and turning, turning sideways, stainless steel, max Ø600 mm, 4 rolling grippers with total height 120 mm included, capacity 250 kg	300	
87945*	Drum turner with motorised grip and turning, tipping forward, stainless steel, max Ø600 mm, max length 900 mm, 4 rolling grippers with total height 120 mm included, capacity 140 kg	300	
87932	Control box for motorised lifting tools, can only be used in combination with motorised lifting tool	200	
87933	Control box for motorised lifting tools, can only be used in combination with motorised lifting tool	300	
87787	Lifting fork, stainless steel, LxW 585x375 mm	70, 90	
87614	Lifting fork, stainless steel, LxW 570x380 mm	200	
87901	Lifting fork, stainless steel, customized, max LxW 800x600 mm	300	

* Control box 87932 or 87933 is required to use motorised tools (additional price)

Special dimensions and other customizations can be quoted upon request.

Grippers for motorised drum turners

All motorised drum turners comes equipped with 4 rolling grippers with a total height 120 mm.

Optional grippers can be selected for an add-on price.

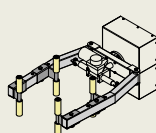

Drum turner 87924 equipped with Gripper A

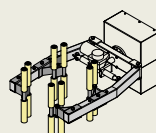

Drum turner 87924 equipped with Gripper B

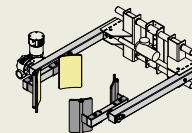

Drum turner 87926 equipped with Gripper C

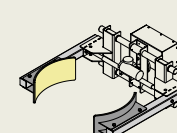

Drum turner 87925 equipped with Gripper D

Model	Art. no.	Gripper	Note
Gripper A	87927	4 rolling grippers, total height 260 mm.	
Gripper B	87928	4 set of double rolling grippers, total height 360 mm, for gripping soft items and items in different shapes (round/square).	
Gripper C	87929	4 curved plates with rubber, height 260 mm, flexible in horizontal direction for gripping items with different diameters.	
Gripper D	87930	2 fixed and curved plates with rubber, for gripping heavy or soft drums/items in the same diameter.	

Ergonomic Electric Tugger

Electric tuggers makes it easy to move heavy loads on wheels. Whether you are moving trolleys, hospital beds, industrial carts, roll containers or other objects on wheels. With an electric tugger it can be done without any physical effort.

An electric tugger move loads across a single level. Therefore, the load has to be placed on something with wheels, such as a trolley or a lift table with wheel chassis. Its operation relies on electric traction. Once the load is attached to the tugger, it generates downward pressure on the wheel through the lever effect. Electric traction generated by this force is what makes it possible to move heavy materials.

All electric tuggers are powered by a powerful and efficient electric motor, which changes heavy material handling into an easy and light task.

- ▶ Extremely user friendly, no certificate or license is needed to operate the machines
- ▶ Protection class IP44
- ▶ Wide range of accessories
- ▶ Speed and acceleration are programmable for free to suit the user's needs
- ▶ Available for the Nordic market



moveXX
driven by brain power

Movexx T1000

Model	Art. no.	Capacity kg	Length mm	Width mm	Height mm	Max speed km/h	Battery capacity	Charger	Motor effect	Weight kg battery excl.	Note
T1000 BASIC	88343	1000	756	440	1056	4,7	22Ah	5A/24V	300W	43	
T1000**	88342	1000	920	438	985	4,7	22Ah	5A/24V	300W	43	
T1000 CLEAN ROOM*	88344	1000	767	462	1055	4,7	22Ah	5A/24V	300W	43	
T1500**	88345	1500	876	483	1177	4,7	22Ah	5A/24V	600W	105	
T1500 CLEAN ROOM*	88347	1500	771	511	1061	4,7	22Ah	5A/24V	600W	105	
T2500	88348	2500	757	511	1278	4,7	75Ah	10A/24V	600W	256	
T3500	88349	3500	915	511	1269	4,7	75Ah	10A/24V	600W	300	

Tool/Hook is not included in the price *Stainless steel **Exchangable battery pack



Movexx T1000 Basic



Movexx T1500



Movexx T2500



Movexx T3500



Movexx T1000 Clean Room



Movexx T1500 Clean Room





 Airports



 Industry



 Waste & Facility



 Retail & Distribution



 Food & Pharma



 Hospitals

Lift trolleys for efficient handling of wheels

- ▶ Good ergonomics
- ▶ Higher working capacity
- ▶ Safe lifting

Wheel Lifter

The Wheel Lifter is designed for best ergonomics and efficiency when heavy wheels are to be lifted in or out of pallet racks. The lifter handles four wheels. The accessory Wheel Trolley is used to smoothly roll the wheels over the floor.

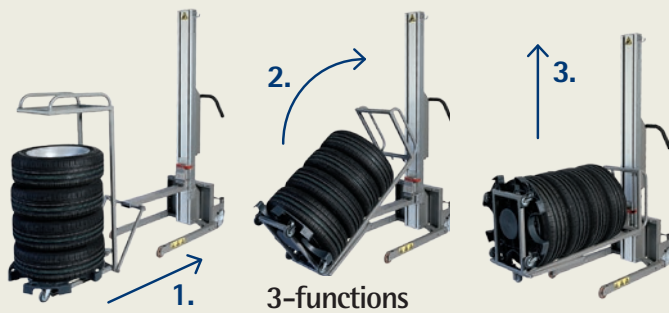

Model	Art.no.	Capacity kg	Lift height mm	Length mm	Width mm	Height mm	Lift time mm/sec	Batteries	Charger	Weight kg	Note
WP 130WL	88270	130	1710	1350	510	1990	125	24V 9Ah	2A/24V	80	

Wheel Mounting Lifter

The Wheel Mounting Lifter is designed for best ergonomics and efficiency when heavy wheels are to be mounted onto a vehicle. Loading wheels directly onto the forks makes it possible to rotate the wheels on the integrated load rollers to find the correct position for the wheel bolts. Two tires can be lifted at a time. The accessory Wheel Trolley makes it possible to lift a stack of 4 wheels directly from the floor to an ergonomic working height.



Model	Art.no.	Capacity kg	Lift height mm	Length mm	Width mm	Height mm	Lift time mm/sec	Batteries	Charger	Weight kg	Note
WP 130WM	88269	130	1235	750	750	1350	125	24V 9Ah	2A/24V	49	

Wheel Trolley - accessory

Used for easy wheel handling. The Wheel Trolley is designed to be used with the Wheel Lifter and the Wheel Mounting Lifter.



Art.no.	Accessory	Fits	Note
88282	Wheel Trolley, handles 4 wheels, one package contains 6 pcs of Wheel Trolleys.	WP 130WL, WM	

AIR - work off the ground safely and easily



AIR is a compact mobile work platform in a modern design.

AIR is easy to use, it rolls freely and easily passes through a standard doorway. This work platform works well in tight spaces and can lift a person with tools and load up to working heights of 5 metres.

AIR minimises the risks of working from long ladders, stepladders, etc. The product is ideally suited for public areas such as hospitals, shopping centres, stores and offices, but also works well in engineering and production facilities.

AIR 2950MA is powered and operated easily from the basket with a joystick at up to 4 km/h in the lowered position and 2 km/h in the raised position. You can slide AIR 2950PA around easily by hand.

- ▶ Easy to use
- ▶ Passes through a standard doorway
- ▶ Stylish design that blends in with its surroundings
- ▶ High lift height
- ▶ Non-slip floor on platform
- ▶ Easy to manoeuvre
- ▶ Lockable main power switch
- ▶ Unloading Tray for tools and materials
- ▶ Self-driven and Push-a-round models
- ▶ Low level between the platform and the floor for easy entry and exit
- ▶ Swing gate that automatically closes when you step on or off the platform

- ▶ AIR is designed for indoor use only and may not be used outdoor or where the floor is not level or where there are strong winds.



EdmoLift AIR easily passes through a normal door opening.



AIR 2950PA



Model	Art. no.	Capacity kg	Total height lowered mm	Total height elevated mm	Platform height elevated mm	Max. working height mm	Length mm	Width mm	Batteries	Self weight kg	Note
AIR 2950PA*	86710	180***	1572	4120	2950	4950	1165	780	2 x 12V 75Ah	300	
AIR 2950MA**	86700	180***	1572	4120	2950	4950	1165	780	2 x 12V 75Ah	320	

*Push-a-round. **Self-driven operation with control from the basket. ***1 person + 100 kg tools and materials.

Goods lift - for both indoor and outdoor environments

LIFTING HEIGHT UP TO 7.5 METRES • MAXIMUM SPACE SAVING

EdmoLift's goods lift is used to bridge the distance between different floors or mezzanines up to 7.5 metres. The goods lift has a strong design with a high lifting height and low minimum height which means that it does not need to be placed in a pit.

The goods lift can be installed against an existing wall or in a separate shaft with interlocking doors. The lift has an external power pack and can be supplied in standard colour, stainless or galvanised steel.

The control includes two automatic stops at floor levels, soft start and stop, two control units, upper and lower limit restriction, interlockings, etc.

PRODUCT FEATURES

- ▶ Lifting height up to 7.5 metres
- ▶ External power pack in lockable box – no machine room required
- ▶ The design makes the goods lift flexible and easy to place
- ▶ Quick and smooth installation
- ▶ Maximum space saving
- ▶ Can be delivered complete with shaft and doors
- ▶ For use indoors and outdoors



External lockable power pack means that a machine room is not needed.



Quick and smooth installation.



Control unit with soft start and stop

TERMS OF DELIVERY



SCOPE OF DELIVERY

All products come complete with manual, tested and including oil. The products undergo trial runs and all functions are tested. The lift tables are electric as standard with 3-phase 400V. 24V on control unit, valve coil and switch for safety frame.

TERMS OF DELIVERY

All prices are Ex Works, import costs and duty fees are not included in the pricings. Packaging costs will be charged.

VALIDATION

EdmoLift reserves the right to change construction details and against typographical errors.

TERMS

Terms according to EdmoLift - Conditions 2018. (www.edmolift.com/ec-2018)

INSTALLATION

Installation is not included unless otherwise agreed. Technician and employer must ensure that the risk of crushing does not occur, that the lifting equipment is used in such a way it is intended for and that official regulations are followed.

COATING

Standard colours RAL 5002, RAL 2010, RAL 7024

PRODUCT DECLARATION

We design and manufacture our products in compliance with applicable EU norms and standards. Products are delivered with the CE marking and declaration of conformity. If the product is not complete it will be delivered with a Type 2B declaration. For example, when the product is to be integrated in a system.

EDMOLIFT WORLDWIDE

OFFICES

Sweden (HQ), Belgium, France, China, Luxembourg, Russia, United Kingdom, Germany, Netherlands.

EXPORT MARKETS

Argentina, Armenia, Australia, Austria, Belgium, Brazil, Canada, Czech Republic, Chile, China, Croatia, Denmark, Egypt, Estonia, Finland, France, Germany, Greece, Hong Kong, Hungary, India, Iran, Iceland, Ireland, Israel, Italy, Japan, Latvia, Lithuania, Madagascar, Mexico, Netherlands, Norway, New Zealand, Peru, Philippines, Poland, Portugal, Romania, Russia, Saudi Arabia, Singapore, Slovakia, Slovenia, South Africa, Spain, Switzerland, Thailand, Turkey, United Arab Emirates, United Kingdom, United States.



EDMOLIFT – A WORLD CLASS GLOBAL PARTNER

EdmoLift is one of the world's largest manufacturer of scissor lift tables, pallet handling products and tools for materials handling. For more than 50 years we have successfully delivered lift tables and solutions for material handling. The biggest customer category is industrial companies, but our lifting solutions are also within distribution, healthcare, service and trade.

Our business concept is to be the supplier offering the most for the money on the market. EdmoLift must also provide added value and high quality so that our products meet our customers' requirements, provide the

best functionality and have a long lifetime. Our products mainly are sold through distributors and subsidiaries in more than 60 countries around the world.

EdmoLift was founded in 1964 by Torbjörn Edmo. The company has its headquarters in beautiful Härnösand in Høga Kusten where we have modern premises for production, development, sales and service. Our experienced and knowledgeable staff can provide a rapid response and good service.

Our goal is to offer the best and most ergonomic, cost-effective solution for your lifting and handling needs.

World class equipment from Sweden!

■ Offices ■ Export markets

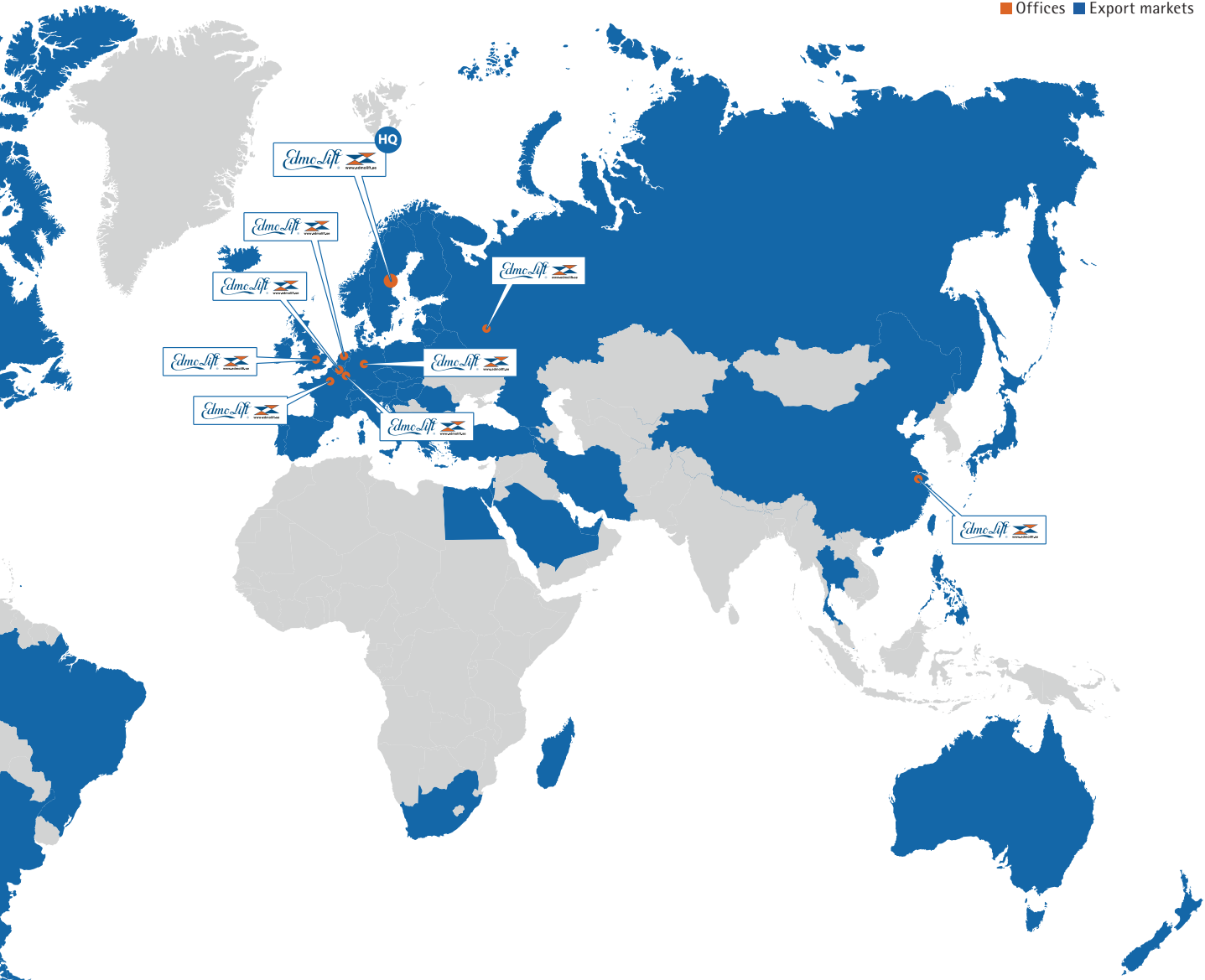

EcoVadis is widely used to determine the responsibility as a supplier towards its employees, society and the environment. Only five per cent of the companies evaluated in an international sustainability analysis reach the highest level - gold. One of these is EdmoLift AB.



EdmoLift GoGreen is a series of products designed for reducing the environmental impact.



EdmoLift is certified according FR2000 - an integrated management system for Quality, Environment, Work Environment, Fire Protection and Expertise. The system is based on ISO 9001, ISO 14001 and SS 62 40 70, as well as the Swedish Work Environment Authority's regulations governing systematic work environment management, AFS 2001:1 and the Swedish Rescue Services Agency's general advice on systematic fire protection, SRVFS 2004:3.



EdmoLift has the highest credit rating a limited liability company can have in Sweden.



In its basic version, EdmoLift lift tables meet the basic requirements according to the lift table standard EN 1570-1. This European Standard specifies the safety requirements for lift tables that are used for lifting and/or lowering of material and/or trained persons accompanying the lift table.



EdmoLift AB
Jägaregatan 11
SE-871 42 Härnösand
Sweden

Tel. +46 (0)611-837 80
Fax. +46 (0)611-51 15 80
E-mail: b2b@edmolift.se

www.edmolift.com